

## 2V<sub>RMS</sub> DirectPath™, 112/106dB Audio Stereo DAC with 32-bit, 384kHz PCM Interface

 Check for Samples: [PCM5141](#), [PCM5142](#)

### FEATURES

- Programmable miniDSP
- Market-Leading Low Out-of-Band Noise
- Selectable Digital-Filter Latency and Performance
- No DC Blocking Capacitors Required
- Integrated Negative Charge Pump
- Internal Pop-Free Control For Sample-Rate Changes Or Clock Halts
- Intelligent Muting System; Soft Up or Down Ramp and Analog Mute For 120dB Mute SNR With Popless Operation
- Integrated High-Performance Audio PLL With BCK Reference To Generate SCK Internally
- Accepts 16-, 24-, And 32-Bit Audio Data

### Typical Performance (3.3V Power Supply)

Parameter	PCM5142	PCM5141
SNR	112dB	106dB
Dynamic Range	112dB	106dB
THD+N @ -1dBFS	-93dB	-92dB
Full Scale Output	2.1V <sub>RMS</sub> (GND center)	
Normal 8x Oversampling Digital Filter Latency: 20t <sub>s</sub>		
Low Latency 8x Oversampling Digital Filter Latency: 3.5t <sub>s</sub>		
Sampling Frequency	8kHz to 384kHz	
System Clock Multiples (f <sub>SCK</sub> ): 64, 128, 192, 256, 384, 512, 768, 1024, 1152, 1536, 2048, 3072; up to 50 MHz		

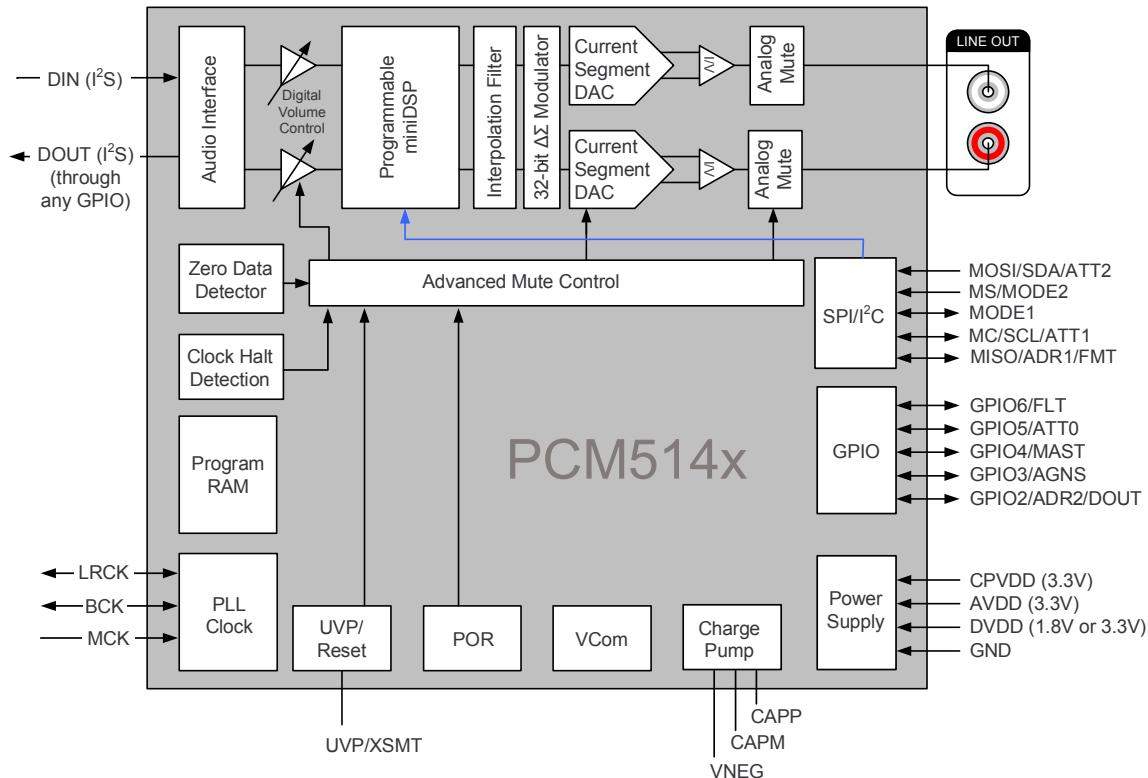

**Figure 1. PCM514x Functional Block Diagram**



Please be aware that an important notice concerning availability, standard warranty, and use in critical applications of Texas Instruments semiconductor products and disclaimers thereto appears at the end of this data sheet.

System Two Cascade, Audio Precision are trademarks of Audio Precision.  
DirectPath is a trademark of Texas Instruments, Inc..



This integrated circuit can be damaged by ESD. Texas Instruments recommends that all integrated circuits be handled with appropriate precautions. Failure to observe proper handling and installation procedures can cause damage.

ESD damage can range from subtle performance degradation to complete device failure. Precision integrated circuits may be more susceptible to damage because very small parametric changes could cause the device not to meet its published specifications.

## OTHER KEY FEATURES

- **PCM Data Formats: I<sup>2</sup>S, Left-Justified, Right-Justified, TDM**
- **SPI or I<sup>2</sup>C Control**
- **Software or Hardware Configuration**
- **Automatic Power-Save Mode When LRCK And BCK Are Deactivated**
- **1.8V or 3.3V Failsafe LVCMOS Digital Inputs**
- **Single Supply Operation:**
  - 3.3V Analog, 1.8V or 3.3V Digital
- **Integrated Power-On Reset**
- **Small 28-pin TSSOP Package**

## APPLICATIONS

- **A/V Receivers**
- **DVD, BD Players**
- **HDTV Receivers**
- **Applications Requiring 2V<sub>RMS</sub> Audio Output**

## DESCRIPTION

The PCM514x devices are a family of monolithic CMOS integrated circuits that include a stereo digital-to-analog converter and additional support circuitry in a small TSSOP package. The PCM514x uses the latest generation of TI's advanced segment-DAC architecture to achieve excellent dynamic performance and improved tolerance to clock jitter.

Members of the PCM514x family integrate a fully programmable miniDSP core, allowing developers to integrate filters, dynamic range controls, custom interpolators and other differentiating features to their products.

The PCM514x provides 2.1V<sub>RMS</sub> ground centered outputs, allowing designers to eliminate DC blocking capacitors on the output, as well as external muting circuits traditionally associated with single supply line drivers.

The integrated line driver surpasses all other charge-pump based line drivers by supporting loads down to 1kΩ. By supporting loads down to 1kΩ, the PCM514x can essentially drive up to 10 products in parallel, such as LCD TV, DVDR, AV Receivers.

The integrated PLL on the device removes the requirement for a system clock (commonly known as master clock), allowing a 3-wire I<sup>2</sup>S connection and reducing system EMI.

In addition, the PLL is completely programmable, allowing the device to become the I<sup>2</sup>S clock master and drive a DSP serial port as a slave. The PLL also accepts a non-standard clock (up to 50MHz) as a source to generate the audio related clock (for example 24.576MHz).

Intelligent clock error and PowerSense undervoltage protection utilizes a two level mute system for pop-free performance. Upon clock error or system power failure, the device digitally attenuates the data (or last known good data), then mutes the analog circuit.

Compared with existing DAC technology, the PCM514x family offers up to 20dB lower out-of-band noise, reducing EMI and aliasing in downstream amplifiers/ADCs. (from traditional 100kHz OBN measurements all the way to 3MHz).

The PCM514x accepts industry-standard audio data formats with 16- to 32-bit data. Sample rates up to 384kHz are supported.

**Table 1. Differences Between PCM514x Devices**

Part Number	Dynamic Range	SNR	THD
PCM5142	112dB	112dB	-93dB
PCM5141	106dB	106dB	-92dB

## DEVICE INFORMATION

### PCM514x pin assignments-1 MODE1 tied DVDD : SPI mode

PCM514x (top view)

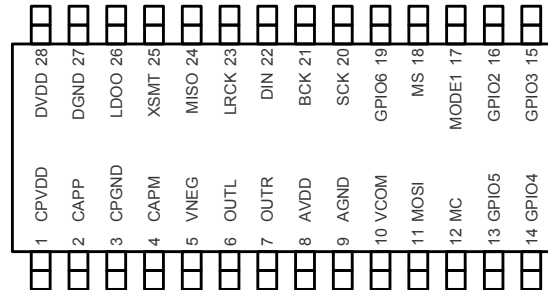

Table 2. PCM514x SPI mode Terminal Functions

TERMINAL		I/O	DESCRIPTION
NAME	PIN		
CPVDD	1	-	Charge pump power supply, 3.3V
CAPP	2	O	Charge pump flying capacitor terminal for positive rail
CPGND	3	-	Charge pump ground
CAPM	4	O	Charge pump flying capacitor terminal for negative rail
VNEG	5	O	Negative charge pump rail terminal for decoupling, -3.3V
OUTL	6	O	Analog output from DAC left channel
OUTR	7	O	Analog output from DAC right channel
AVDD	8	-	Analog power supply, 3.3V
AGND	9	-	Analog ground
VCOM	10	O	VCOM output (Optional mode selected by register; default setting is VREF mode.) When in VREF mode (default), this pin ties to GND. When in VCOM mode, decoupling capacitor to GND is required.
MOSI	11	I	Input data for SPI <sup>(1)</sup>
MC	12	I	Input clock for SPI <sup>(1)</sup>
GPIO5	13	I/O	General purpose digital input and output port
GPIO4	14	I/O	General purpose digital input and output port
GPIO3	15	I/O	General purpose digital input and output port
GPIO2	16	I/O	General purpose digital input and output port
MODE1	17	I	Mode control selection pin <sup>(1)</sup>
MS (MODE2)	18	I	<ul style="list-style-type: none"> <li>MODE1=Low, MODE2=Low : Hardwired mode</li> <li>MODE1=Low, MODE2=High : I<sup>2</sup>C mode</li> <li>MODE1=High : SPI mode, MODE2 pin changes MS pin (chip select for SPI)</li> </ul>
GPIO6	19	I/O	General purpose digital input and output port
SCK	20	I	System clock input <sup>(1)</sup>
BCK	21	I/O	Audio data bit clock input (slave) or output (master) <sup>(1)</sup>
DIN	22	I	Audio data input <sup>(1)</sup>
LRCK	23	I/O	Audio data word clock input (slave) or output (master) <sup>(1)</sup>
MISO (GPIO1)	24	I/O	Primary output data for SPI readback Secondary; general purpose digital input/output port controlled by register
XSMT	25	I	Soft mute control <sup>(1)</sup> Soft mute (Low) / soft un-mute (High)

(1) Failsafe LVCMOS Schmitt trigger input.

**Table 2. PCM514x SPI mode Terminal Functions (continued)**

TERMINAL		I/O	DESCRIPTION
NAME	PIN		
LDOO	26	-	Internal logic supply rail terminal for decoupling, 1.8V
DGND	27	-	Digital ground
DVDD	28	-	Digital power supply, 3.3V or 1.8V

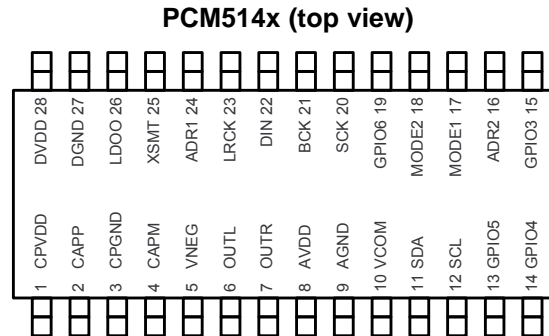
**PCM514x pin assignments-2 MODE1 tied DGND and MODE2 tied DVDD : I<sup>2</sup>C mode**

**Table 3. PCM514x I<sup>2</sup>C mode Terminal Functions**

TERMINAL		I/O	DESCRIPTIONS
NAME	PIN		
CPVDD	1	-	Charge pump power supply, 3.3V
CAPP	2	O	Charge pump flying capacitor terminal for positive rail
CPGND	3	-	Charge pump ground
CAPM	4	O	Charge pump flying capacitor terminal for negative rail
VNEG	5	O	Negative charge pump rail terminal for decoupling, -3.3V
OUTL	6	O	Analog output from DAC left channel
OUTR	7	O	Analog output from DAC right channel
AVDD	8	-	Analog power supply, 3.3V
AGND	9	-	Analog ground
VCOM	10	I	VCOM output (Optional mode selected by register; default setting is VREF mode.) When in VREF mode (default), this pin ties to GND. When in VCOM mode, decoupling capacitor to GND is required.
SDA	11	I/O	Input data for I <sup>2</sup> C <sup>(1)(2)</sup>
SCL	12	I	Input clock for I <sup>2</sup> C <sup>(2)</sup>
GPIO5	13	I/O	General purpose digital input and output port
GPIO4	14	I/O	General purpose digital input and output port
GPIO3	15	I/O	General purpose digital input and output port
ADR2	16	I	2nd LSB address select bit for I <sup>2</sup> C
MODE1	17	I	Mode-control selection pins <sup>(2)</sup>
MODE2	18	I	<ul style="list-style-type: none"> <li>• MODE1=Low, MODE2=Low : Hardwired mode</li> <li>• MODE1=Low, MODE2=High : I<sup>2</sup>C mode</li> <li>• MODE1=High : SPI mode, MODE2 pin changes MS pin (chip select for SPI)</li> </ul>
GPIO6	19	I/O	General purpose digital input and output port
SCK	20	I	System clock input <sup>(2)</sup>
BCK	21	I/O	Audio data bit clock input (slave) or output (master) <sup>(2)</sup>
DIN	22	I	Audio data input <sup>(2)</sup>
LRCK	23	I/O	Audio data word clock input (slave) or output (master) <sup>(2)</sup>
ADR1	24	I	LSB address select bit for I <sup>2</sup> C
XSMT	25	I	Soft mute control : Soft mute (Low) / soft un-mute (High) <sup>(2)</sup>
LDOO	26	-	Internal logic supply rail terminal for decoupling, 1.8V
DGND	27	-	Digital ground
DVDD	28	-	Digital power supply, 3.3V or 1.8V

(1) Open-drain configuration in out mode.  
 (2) Failsafe LVCMOS Schmitt trigger input.

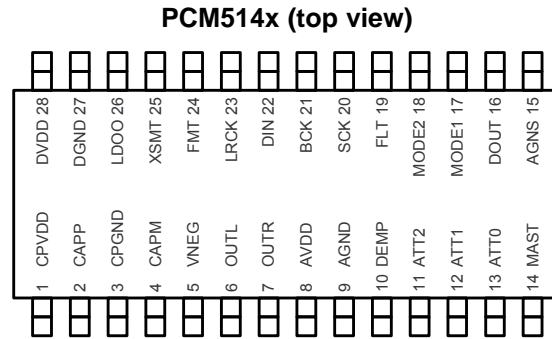
**PCM514x pin assignments-3 MODE1 tied DGND and MODE2 tied DGND : Hardwired mode**



The H/W mode has digital gain and attenuation level control by decoding external ATT2 (11 pin), ATT1 (12 pin), and ATT0 (pin 13). Table 1 shows the pins used to set gain and attenuation levels.

**Table 4. Gain and Attenuation in Hardware Mode**

ATT pin condition (ATT2 : ATT1 : ATT0)	Gain and Attenuation level
( 0 0 0 )	0 dB
( 0 0 1 )	+ 3 dB
( 0 1 0 )	+ 6 dB
( 0 1 1 )	+ 9 dB
( 1 0 0 )	+ 12 dB
( 1 0 1 )	+ 15 dB
( 1 1 0 )	- 6 dB
( 1 1 1 )	- 3 dB

**Table 5. PCM514x Hardwired mode Terminal Functions**

Terminal		I/O	Description
Name	Pin		
CPVDD	1	-	Charge pump power supply, 3.3V
CAPP	2	O	Charge pump flying capacitor terminal for positive rail
CPGND	3	-	Charge pump ground
CAPM	4	O	Charge pump flying capacitor terminal for negative rail
VNEG	5	O	Negative charge pump rail terminal for decoupling, -3.3V
OUTL	6	O	Analog output from DAC left channel
OUTR	7	O	Analog output from DAC right channel
AVDD	8	-	Analog power supply, 3.3V
AGND	9	-	Analog ground
DEMP	10	I	De-emphasis control for 44.1kHz sampling rate <sup>(1)</sup> : Off (Low) / On (High)
ATT2	11	I	Digital gain and attenuation control pin <sup>(1)</sup>
ATT1	12	I	Digital gain and attenuation control pin <sup>(1)</sup>
ATT0	13	I	Digital gain and attenuation control pin
MAST	14	I	I <sup>2</sup> S Master clock select pin : Master (High) BCK/LRCK outputs, Slave (Low) BCK/LRCK inputs
AGNS	15	I	Analog gain selector : 0dB 2V <sub>RMS</sub> output (Low), -6dB 1V <sub>RMS</sub> output (High)
GPO	16	O	General Purpose Output (Low level)

(1) Failsafe LVCMOS Schmitt trigger input.

**Table 5. PCM514x Hardwired mode Terminal Functions (continued)**

Terminal		I/O	Description
Name	Pin		
MODE1	17	I	Mode-control selection pins <sup>(2)</sup> <ul style="list-style-type: none"> <li>• MODE1=Low, MODE2=Low : Hardwired mode</li> <li>• MODE1=Low, MODE2=High : I<sup>2</sup>C mode</li> <li>• MODE1=High : SPI mode, MODE2 pin changes MS pin (chip select for SPI)</li> </ul>
MODE2	18	I	
FLT	19	I	Filter select : Normal latency (Low) / Low latency (High)
SCK	20	I	System clock input <sup>(2)</sup>
BCK	21	I/O	Audio data bit clock input <sup>(2)</sup>
DIN	22	I	Audio data input <sup>(2)</sup>
LRCK	23	I/O	Audio data word clock input <sup>(2)</sup>
FMT	24	I	Audio format selection : I <sup>2</sup> S (Low) / Left justified (High)
XSMT	25	I	Soft mute control : Soft mute (Low) / soft un-mute (High) <sup>(2)</sup>
LDOO	26	-	Internal logic supply rail terminal for decoupling, 1.8V
DGND	27	-	Digital ground
DVDD	28	-	Digital power supply, 3.3V or 1.8V

(2) Failsafe LVCMOS Schmitt trigger input.

## ABSOLUTE MAXIMUM RATINGS

over operating free-air temperature range (unless otherwise noted)

		VALUE	UNIT
Supply Voltage	AVDD, CPVDD, DVDD	–0.3 to 3.9	V
	LDOO with DVDD at 1.8V (See <a href="#">Typical Applications Circuits</a> )	–0.3 to 2.25	
Digital Input Voltage	DVDD at 1.8V	–0.3 to 2.25	
	DVDD at 3.3V	–0.3 to 3.9	
Analog Input Voltage		–0.3 to 3.9	
Operating Temperature Range		–25 to 85	°C
Storage Temperature Range		–65 to 150	

## THERMAL CHARACTERISTICS

over operating free-air temperature range (unless otherwise noted)

PARAMETER		TEST CONDITIONS	MIN	TYP	MAX	UNIT
$\theta_{JA}$	Theta JA	High K		72.2		°C/W
$\theta_{JC}$	Theta JC	Top		17.5		
$\theta_{JB}$	Theta JB			35.0		
$\Psi_{JT}$	Psi JT			0.4		
$\Psi_{JB}$	Psi JB			34.5		



## ELECTRICAL CHARACTERISTICS

All specifications at  $T_A = 25^\circ\text{C}$ ,  $AV_{DD} = CPV_{DD} = DV_{DD} = 3.3\text{V}$ ,  $f_S = 48\text{kHz}$ , system clock =  $512f_S$  and 24-bit data unless otherwise noted.

PARAMETER		TEST CONDITIONS	MIN	TYP	MAX	UNIT
	Resolution		16	24	32	Bits
<b>Data Format (PCM Mode)</b>						
	Audio data interface format		I <sup>2</sup> S, left justified, right justified and TDM			
	Audio data bit length		16, 24, 32-bit acceptable			
	Audio data format		MSB First, 2s Complement			
$f_S^{(1)}$	Sampling frequency		8		384	kHz
<b>Clocks</b>						
	System clock frequency		64, 128, 192, 256, 384, 512, 768, 1024, 1152, 1536, 2048, or 3072 $f_{SCK}$ , up to 50MHz			
	PLL Input Frequency (SCL Clock Frequency 400 kHz)	Clock divider uses fractional divide $D > 0$ , $P=1$	6.7		20	MHz
		Clock divider uses integer divide $D = 0$ , $P=1$	1		20	MHz
<b>Digital Input/Output</b>						
<i>Logic Family: 3.3V LVCMOS compatible</i>						
$V_{IH}$	Input logic level		0.7×DV <sub>DD</sub>		V	
$V_{IL}$			0.3×DV <sub>DD</sub>			
$I_{IH}$	Input logic current	$V_{IN} = V_{DD}$		10	μA	
$I_{IL}$		$V_{IN} = 0\text{V}$		-10		
$V_{OH}$	Output logic level	$I_{OH} = -4\text{mA}$	0.8×DV <sub>DD</sub>		V	
$V_{OL}$		$I_{OL} = 4\text{mA}$	0.22×DV <sub>D</sub> D			
<i>Logic Family 1.8V LVCMOS compatible</i>						
$V_{IH}$	Input logic level		0.7×DV <sub>DD</sub>		V	
$V_{IL}$			0.3×DV <sub>DD</sub>			
$I_{IH}$	Input logic current	$V_{IN} = V_{DD}$		10	μA	
$I_{IL}$		$V_{IN} = 0\text{V}$		-10		
$V_{OH}$	Output logic level	$I_{OH} = -2\text{mA}$	0.8×DV <sub>DD</sub>		V	
$V_{OL}$		$I_{OL} = 2\text{mA}$	0.22×DV <sub>D</sub> D			

(1) One sample time  $t_s$  defined as the reciprocal of the sampling frequency.  $1t_s = 1/f_S$

## ELECTRICAL CHARACTERISTICS (continued)

All specifications at  $T_A = 25^\circ\text{C}$ ,  $AV_{DD} = CPV_{DD} = DV_{DD} = 3.3\text{V}$ ,  $f_S = 48\text{kHz}$ , system clock =  $512f_S$  and 24-bit data unless otherwise noted.

PARAMETER	TEST CONDITIONS	MIN	TYP	MAX	UNIT	
<b>Dynamic Performance (PCM Mode)<sup>(2)(3)</sup> (Values shown for two devices PCM5142 / PCM5141)</b>						
THD+N at -1 dB <sup>(3)</sup>	$f_S = 48\text{kHz}$	-93	-92	-83	-82	dB
	$f_S = 96\text{kHz}$	-93	-92			
	$f_S = 192\text{kHz}$	-93	-92			
Dynamic range <sup>(3)</sup>	EIAJ, A-weighted, $f_S = 48\text{kHz}$	106	100	112	106	
	EIAJ, A-weighted, $f_S = 96\text{kHz}$			112	106	
	EIAJ, A-weighted, $f_S = 192\text{kHz}$			112	106	
Signal-to-noise ratio <sup>(3)</sup>	EIAJ, A-weighted, $f_S = 48\text{kHz}$			112	106	
	EIAJ, A-weighted, $f_S = 96\text{kHz}$			112	106	
	EIAJ, A-weighted, $f_S = 192\text{kHz}$			112	106	
Signal to noise ratio with analog mute <sup>(3)(4)</sup>	EIAJ, A-weighted, $f_S = 48\text{kHz}$	113		123		
	EIAJ, A-weighted, $f_S = 96\text{kHz}$	113		123		
	EIAJ, A-weighted, $f_S = 192\text{kHz}$	113		123		
Channel Separation	$f_S = 48\text{kHz}$	100	95	109	103	
	$f_S = 96\text{kHz}$	100	95	109	103	
	$f_S = 192\text{kHz}$	100	95	109	103	

(2) Filter condition: THD+N: 20Hz HPF, 20kHz AES17 LPF Dynamic range: 20Hz HPF, 20kHz AES17 LPF, A-weighted Signal-to-noise ratio: 20Hz HPF, 20kHz AES17 LPF, A-weighted Channel separation: 20Hz HPF, 20kHz AES17 LPF Analog performance specifications are measured using the System Two Cascade™ audio measurement system by Audio Precision™ in the RMS mode.

(3) Output load is 10kΩ, with 470Ω output resistor and a 2.2nF shunt capacitor (see recommended output filter).

(4) Assert XSMT or both L-ch and R-ch PCM data are BPZ

**ELECTRICAL CHARACTERISTICS (continued)**

All specifications at  $T_A = 25^\circ\text{C}$ ,  $AV_{DD} = CPV_{DD} = DV_{DD} = 3.3\text{V}$ ,  $f_S = 48\text{kHz}$ , system clock =  $512f_S$  and 24-bit data unless otherwise noted.

PARAMETER	TEST CONDITIONS	MIN	TYP	MAX	UNIT
<b>Analog Output</b>					
Output voltage			2.1		$V_{RMS}$
Gain error		-6	$\pm 2.0$	6	% of FSR
Gain mismatch, channel-to-channel		-6	$\pm 0.5$	6	% of FSR
Bipolar zero error	At bipolar zero	-5	$\pm 1.0$	5	mV
Load impedance		1			$k\Omega$
<b>Filter Characteristics–1: Normal (8x)</b>					
Pass band				$0.45f_S$	
Stop band		$0.55f_S$			
Stop band attenuation		-60			dB
Pass-band ripple				$\pm 0.02$	
Delay time			$20t_S$		s
<b>Filter Characteristics–2: Low Latency (8x)</b>					
Pass band				$0.47f_S$	
Stop band		$0.55f_S$			
Stop band attenuation		-52			dB
Pass-band ripple				$\pm 0.0001$	
Delay time			$3.5t_S$		s
<b>Filter Characteristics–3: Asymmetric FIR (8x)</b>					
Pass band				$0.40f_S$	
Stop band		$0.72f_S$			
Stop band attenuation		-52			dB
Pass-band ripple				$\pm 0.05$	
Delay time			$1.2t_S$		s
<b>Filter Characteristics–4: High-Attenuation (8x)</b>					
Pass band				$0.45f_S$	
Stop band		$0.45f_S$			
Stop band attenuation		-100			dB
Pass-band ripple				$\pm 0.0005$	
Delay time			$33.7t_S$		s

**ELECTRICAL CHARACTERISTICS (continued)**

All specifications at  $T_A = 25^\circ\text{C}$ ,  $AV_{DD} = CPV_{DD} = DV_{DD} = 3.3\text{V}$ ,  $f_S = 48\text{kHz}$ , system clock =  $512f_S$  and 24-bit data unless otherwise noted.

PARAMETER		TEST CONDITIONS	MIN	TYP	MAX	UNIT
<b>Power Supply Requirements</b>						
DV <sub>DD</sub>	Digital supply voltage	Target DV <sub>DD</sub> = 1.8V	1.65	1.8	1.95	VDC
DV <sub>DD</sub>	Digital supply voltage	Target DV <sub>DD</sub> = 3.3V	3.0	3.3	3.6	VDC
AV <sub>DD</sub>	Analog supply voltage		3.0	3.3	3.6	
CPV <sub>DD</sub>	Charge-pump supply voltage		3.0	3.3	3.6	
I <sub>DD</sub>	DV <sub>DD</sub> supply current at 1.8V <sup>(5)</sup>	f <sub>S</sub> = 48kHz, Input is Bipolar Zero data		11	14	mA
		f <sub>S</sub> = 96kHz, Input is Bipolar Zero data		12		
		f <sub>S</sub> = 192kHz, Input is Bipolar Zero data		14		
I <sub>DD</sub>	DV <sub>DD</sub> supply current at 1.8V <sup>(6)</sup>	f <sub>S</sub> = 48kHz, Input is 1kHz -1dBFS data		11	14	mA
		f <sub>S</sub> = 96kHz, Input is 1kHz -1dBFS data		12		
		f <sub>S</sub> = 192kHz, Input is 1kHz -1dBFS data		14		
I <sub>DD</sub>	DV <sub>DD</sub> supply current at 1.8V <sup>(7)</sup>	f <sub>S</sub> = N/A, Power Down Mode		0.3	0.6	mA
I <sub>DD</sub>	DV <sub>DD</sub> supply current at 3.3V <sup>(5)</sup>	f <sub>S</sub> = 48kHz, Input is Bipolar Zero data		12	15	mA
		f <sub>S</sub> = 96kHz, Input is Bipolar Zero data		13		
		f <sub>S</sub> = 192kHz, Input is Bipolar Zero data		15		
I <sub>DD</sub>	DV <sub>DD</sub> supply current at 3.3V <sup>(6)</sup>	f <sub>S</sub> = 48kHz, Input is 1kHz -1dBFS data		12	15	mA
		f <sub>S</sub> = 96kHz, Input is 1kHz -1dBFS data		13		
		f <sub>S</sub> = 192kHz, Input is 1kHz -1dBFS data		15		
I <sub>DD</sub>	DV <sub>DD</sub> supply current at 3.3V <sup>(7)</sup>	f <sub>S</sub> = N/A, Power Down Mode		0.5	0.8	mA
I <sub>CC</sub>	AV <sub>DD</sub> / CPV <sub>DD</sub> Supply Current <sup>(5)</sup>	f <sub>S</sub> = 48kHz, Input is Bipolar Zero data		11	16	mA
		f <sub>S</sub> = 96kHz, Input is Bipolar Zero data		11		
		f <sub>S</sub> = 192kHz, Input is Bipolar Zero data		11		
I <sub>CC</sub>	AV <sub>DD</sub> / CPV <sub>DD</sub> Supply Current <sup>(6)</sup>	f <sub>S</sub> = 48kHz, Input is 1kHz -1dBFS data		24	32	mA
		f <sub>S</sub> = 96kHz, Input is 1kHz -1dBFS data		24		
		f <sub>S</sub> = 192kHz, Input is 1kHz -1dBFS data		24		
I <sub>CC</sub>	AV <sub>DD</sub> / CPV <sub>DD</sub> Supply Current <sup>(7)</sup>	f <sub>S</sub> = N/A, Power Down Mode		0.2	0.4	mA
	Power Dissipation, DV <sub>DD</sub> = 1.8V <sup>(5)</sup>	f <sub>S</sub> = 48kHz, Input is Bipolar Zero data		59.4	78	mW
		f <sub>S</sub> = 96kHz, Input is Bipolar Zero data		61.2		
		f <sub>S</sub> = 192kHz, Input is Bipolar Zero data		64.8		
	Power Dissipation, DV <sub>DD</sub> = 1.8V <sup>(6)</sup>	f <sub>S</sub> = 48kHz, Input is 1kHz -1dBFS data		99	130.8	mW
		f <sub>S</sub> = 96kHz, Input is 1kHz -1dBFS data		100.8		
		f <sub>S</sub> = 192kHz, Input is 1kHz -1dBFS data		104.4		
	Power Dissipation, DV <sub>DD</sub> = 1.8V <sup>(7)</sup>	f <sub>S</sub> = N/A, Power Down Mode		1.2		mW
	Power Dissipation, DV <sub>DD</sub> = 3.3V <sup>(5)</sup>	f <sub>S</sub> = 48kHz, Input is Bipolar Zero data		79.2	103	mW
		f <sub>S</sub> = 96kHz, Input is Bipolar Zero data		82.5		
		f <sub>S</sub> = 192kHz, Input is Bipolar Zero data		89.1		
	Power Dissipation, DV <sub>DD</sub> = 3.3V <sup>(6)</sup>	f <sub>S</sub> = 48kHz, Input is 1kHz -1dBFS data		118.8	155	mW
		f <sub>S</sub> = 96kHz, Input is 1kHz -1dBFS data		122.1		
		f <sub>S</sub> = 192kHz, Input is 1kHz -1dBFS data		128.7		
	Power Dissipation, DV <sub>DD</sub> = 3.3V <sup>(7)</sup>	f <sub>S</sub> = N/A, Power Down Mode		2.3	4.0	mW

(5) Input is Bipolar Zero data.

(6) Input is 1kHz -1dBFS data

(7) Power Down Mode, with LRCK, BCK, and SCK halted at Low level.

**TYPICAL CHARACTERISTICS**

All specifications at  $T_A = 25^\circ\text{C}$ ,  $AV_{DD} = CPV_{DD} = DV_{DD} = 3.3\text{V}$ ,  $f_S = 48\text{kHz}$ , system clock =  $512 f_S$  and 24-bit data unless otherwise noted.

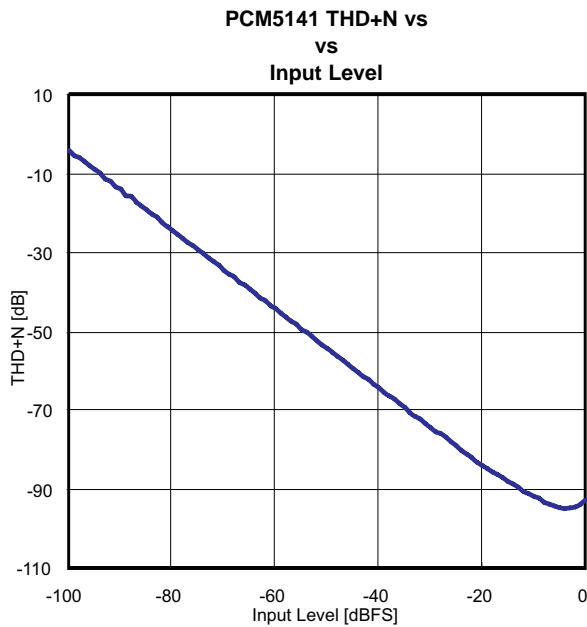

Figure 2.

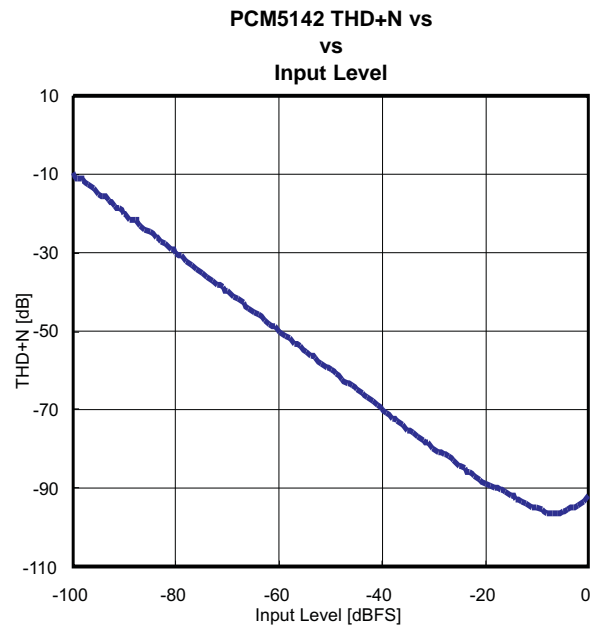

Figure 3.

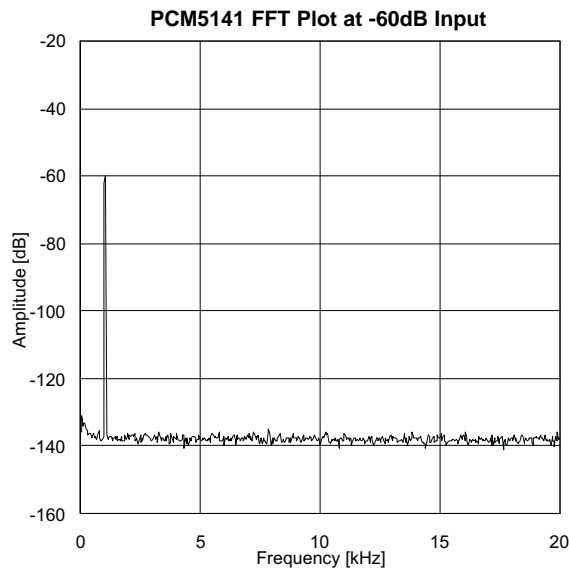

Figure 4.

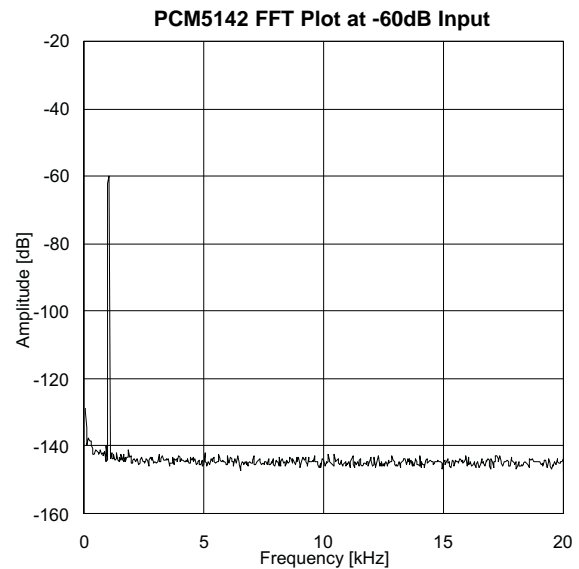

Figure 5.

**TYPICAL CHARACTERISTICS (continued)**

All specifications at  $T_A = 25^\circ\text{C}$ ,  $AV_{DD} = CPV_{DD} = DV_{DD} = 3.3\text{V}$ ,  $f_S = 48\text{kHz}$ , system clock =  $512 f_S$  and 24-bit data unless otherwise noted.

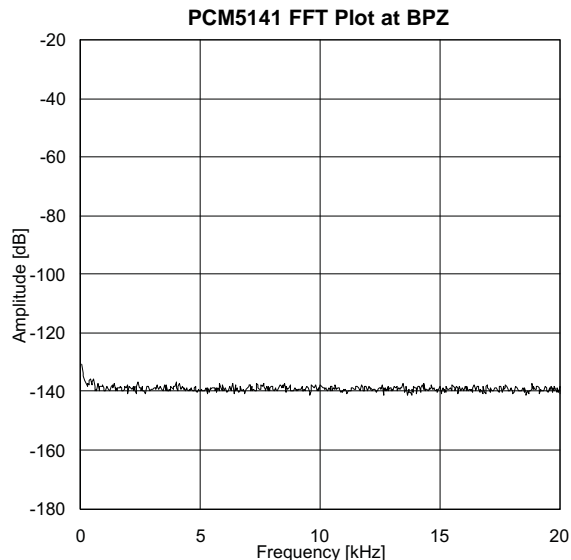

Figure 6.

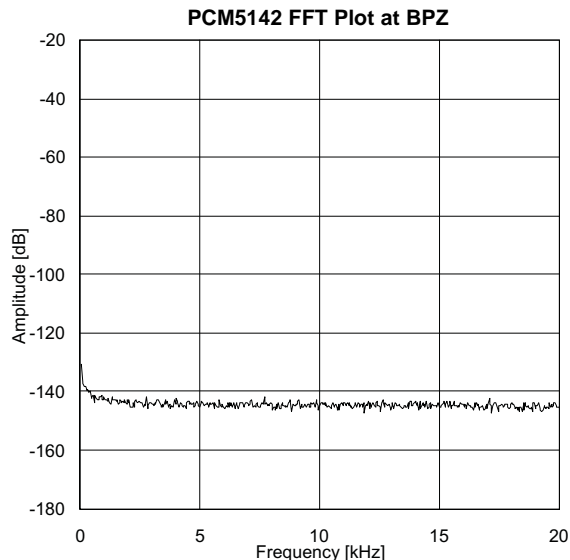

Figure 7.

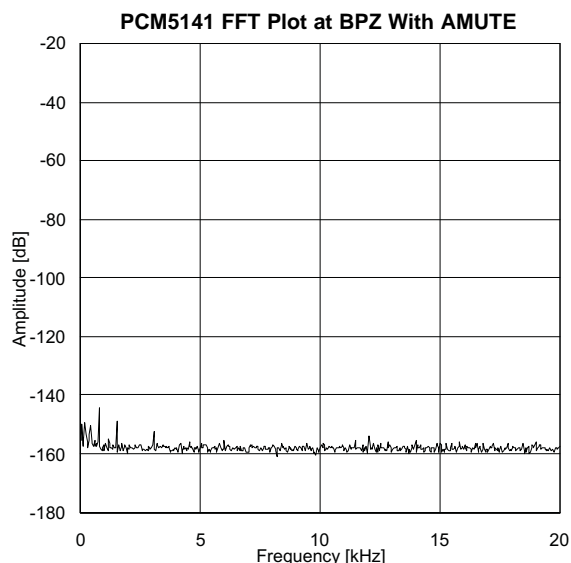

Figure 8.

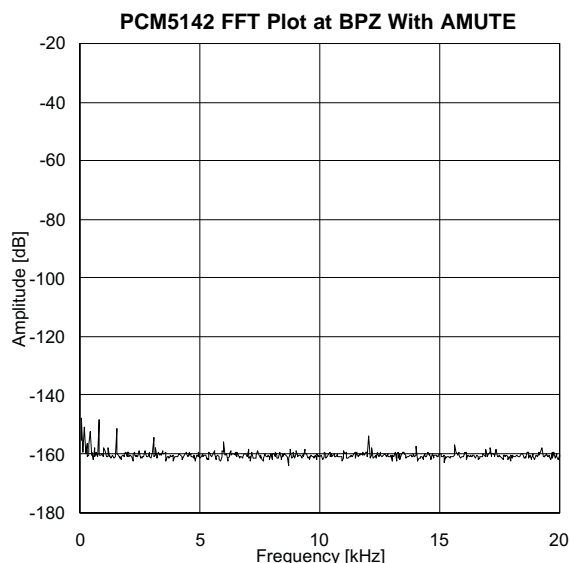
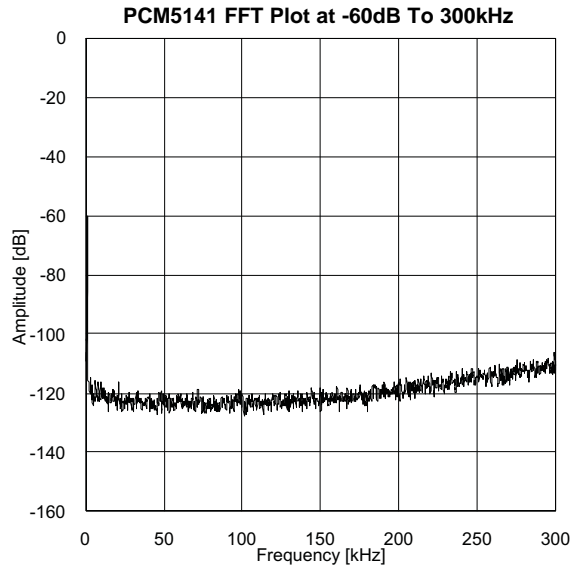

Figure 9.

**TYPICAL CHARACTERISTICS (continued)**

All specifications at  $T_A = 25^\circ\text{C}$ ,  $AV_{DD} = CPV_{DD} = DV_{DD} = 3.3\text{V}$ ,  $f_S = 48\text{kHz}$ , system clock =  $512 f_S$  and 24-bit data unless otherwise noted.



**Figure 10.**

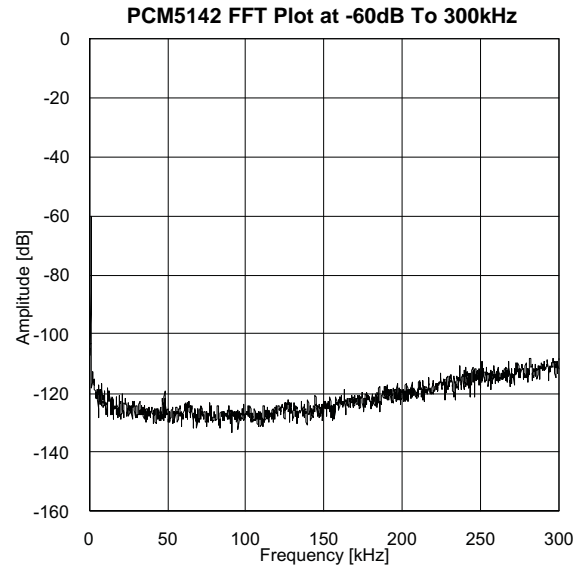

**Figure 11.**

### APPLICATION INFORMATION

#### Typical Application Circuits

The PCM514x devices can be operated in a variety of configurations to support a wide range of applications. Figure 12 through Figure 21 show different combinations of power supplies, control methods, and VCOM/VREF usage.

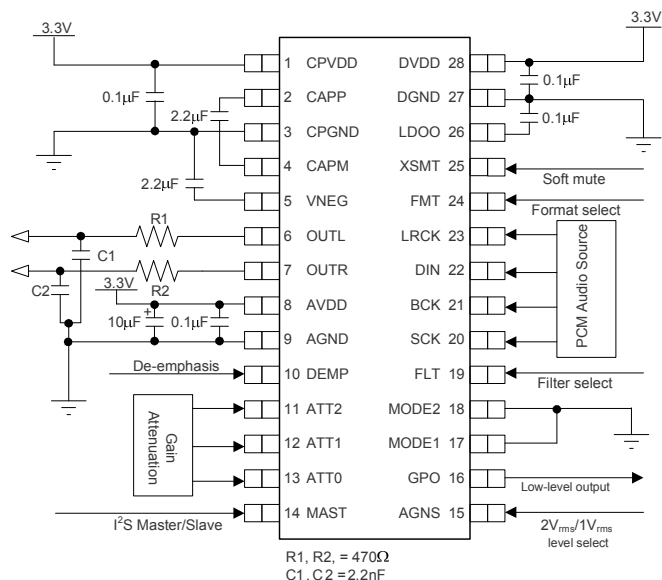

Figure 12. Hardwired Control Mode, DVDD=3.3V

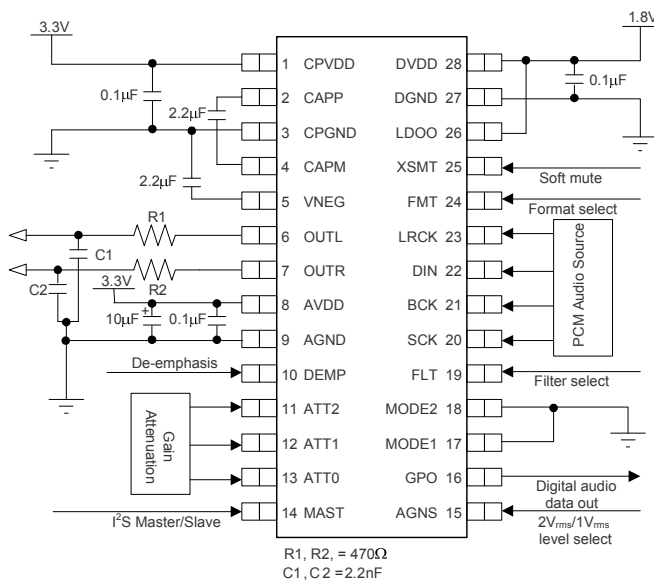

Figure 13. Hardwired Control Mode, DVDD=1.8V

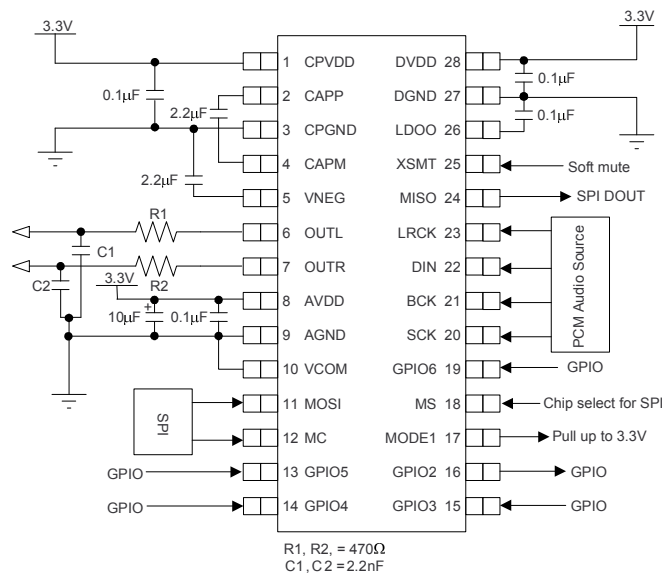

Figure 14. SPI Control, VREF Mode, DVDD=3.3V

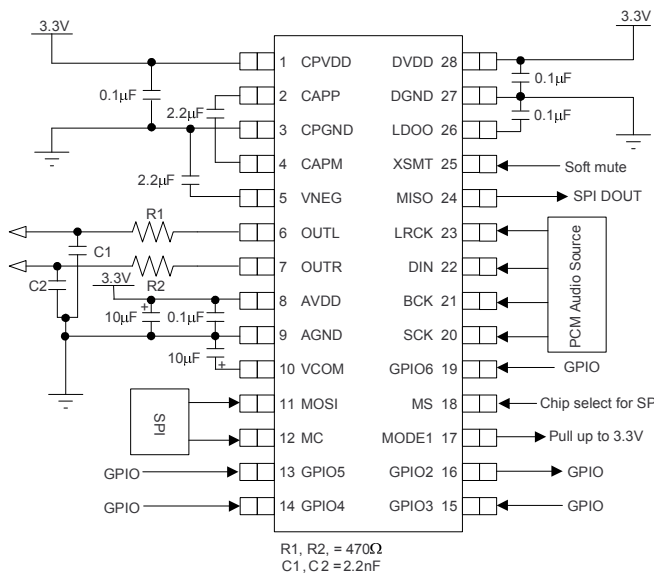

Figure 15. SPI Control, VCOM Mode, DVDD=3.3V



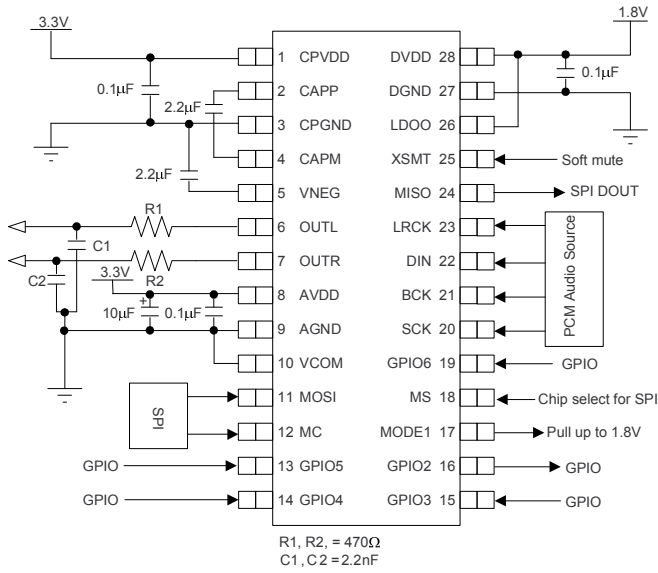

Figure 16. SPI Control, VREF Mode, DVDD=1.8V

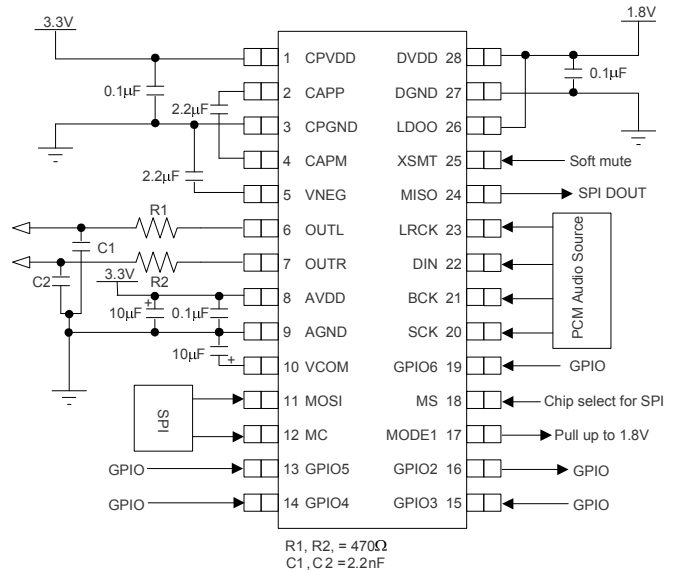

Figure 17. SPI Control, VCOM Mode, DVDD=1.8V

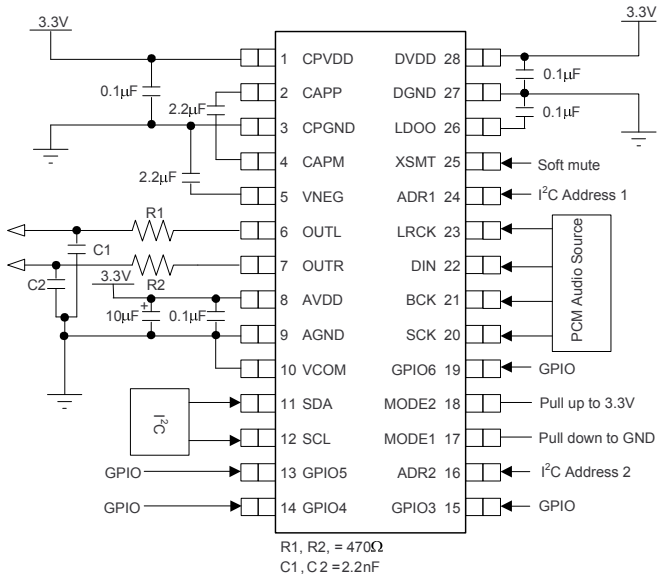

Figure 18. I²C Control, VREF Mode, DVDD=3.3V

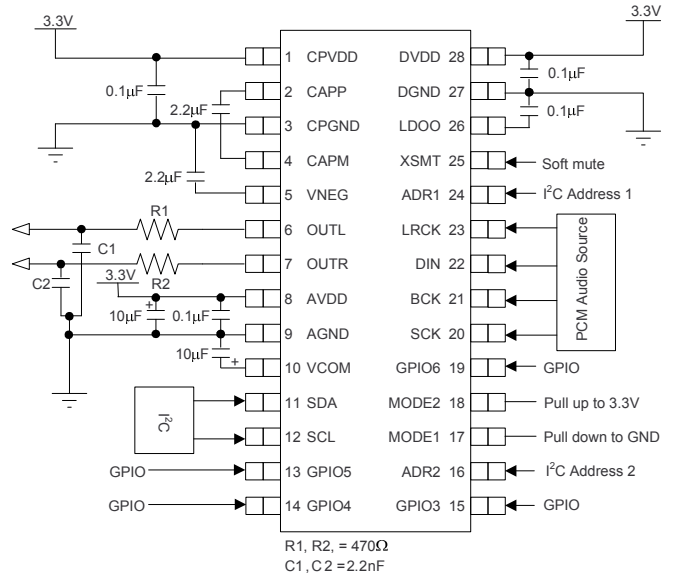

Figure 19. I²C Control, VCOM Mode, DVDD=3.3V

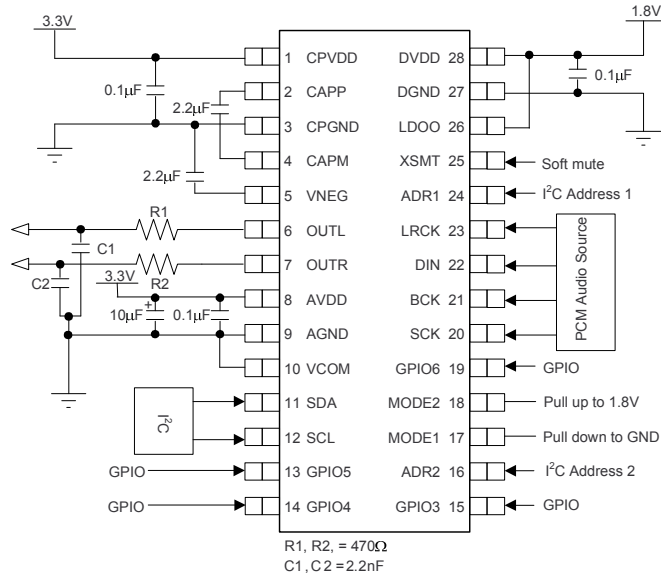

Figure 20. I²C Control, VREF Mode, DVDD=1.8V

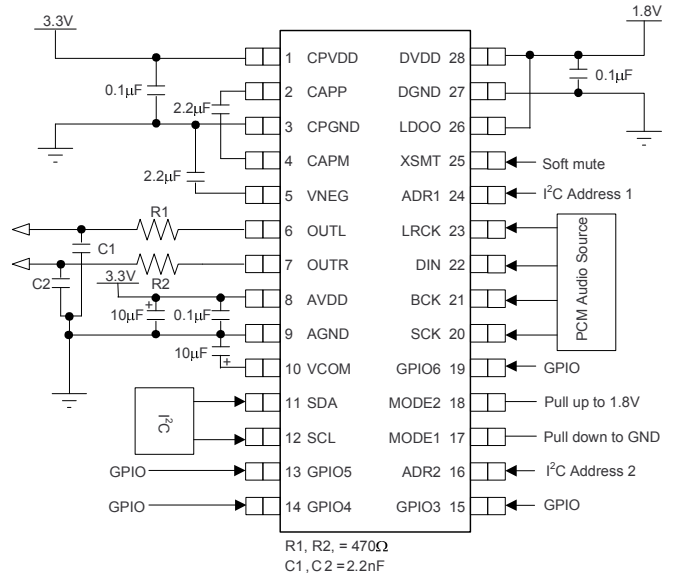

Figure 21. I²C Control, VCOM Mode, DVDD=1.8V

## Analog Outputs

The PCM514x devices include a two-channel DAC, with single-ended outputs. The full-scale output voltage is  $2.1V_{\text{rms}}$  with ground center output. A dc-coupled load is supported in addition to an ac-coupled load, if the load resistance conforms to the specification. The PCM514x DAC outputs on the OUTL and OUTR terminals have market-leading low out-of-band noise, which offer up to 20dB lower out-of-band noise compared with existing DAC technology.

Most applications require an external low-pass RC filter ( $470\Omega + 2.2\text{nF}$ ) to provide sufficient out-of-band noise rejection. This RC filter provides the added advantage of improved protection against ESD damage. Further discussion of DAC post-filter circuits is provided in the *PCM514x Application Reference Guide*, SLAU345.

## Voltage Reference and Output Levels

The PCM514x has an internal, fixed band-gap reference voltage, with default operation in VREF mode. No external decoupling capacitor is required for this mode. VREF mode provides  $2.1V_{\text{rms}}$  full-scale output at both AVDD levels.

The PCM514x can be operated with a common-mode voltage output (VCOM mode) at the VCOM pin by setting Page 1, Register 1, D(0) to 1. In this mode, an external decoupling capacitor is required.

When using this DAC in VREF mode, the output-signal voltage is independent of the power-supply voltage: The D/A conversion gain in VREF mode yields a  $2.1V_{\text{rms}}$  output voltage with a digital full-scale input. However, in VREF mode, an output waveform may clip due to the limitations that may be present in the analog power supply voltage. On the other hand, the full-scale output voltage in VCOM mode is proportional to the analog power supply AVDD. Example,  $(2.1 \times AVDD / 3.3) V_{\text{rms}}$ .

## Mode Switching Sequence, From VREF Mode to VCOM Mode

Following register setting sequence is recommended for changing VREF mode to VCOM mode.

- |                        |   |
|------------------------|---|
| 1. Page 0 / Register 2 | RQST = 1: Standby mode                            |
| 2. Page 1 / Register 8 | RCMF = 1: Fast ramp up → on                       |
| 3. Page 1 / Register 9 | VCPD = 0: VCOM is power on                        |
| 4.                     | Wait 3ms with external capacitor = $1\mu\text{F}$ |
| 5. Page 1 / Register 8 | RCMF = 0: Fast ramp up → off                      |
| 6. Page 1 / Register 1 | OSEL = 1: VCOM mode                               |
| 7. Page 0 / Register 2 | RQST = 0: Normal mode                             |

### Recommended Output Filter for the PCM514x

The diagram in [Figure 22](#) shows the recommended output filter for the PCM514x. The new PCM514x next-generation current segment architecture offers excellent out-of-band noise, making a traditional 20kHz low pass filter a thing of the past.

The RC settings below offer a -3dB filter point at 153kHz (approx), giving the DAC the ability to reproduce virtually all frequencies through to it's maximum sampling rate of 384kHz.

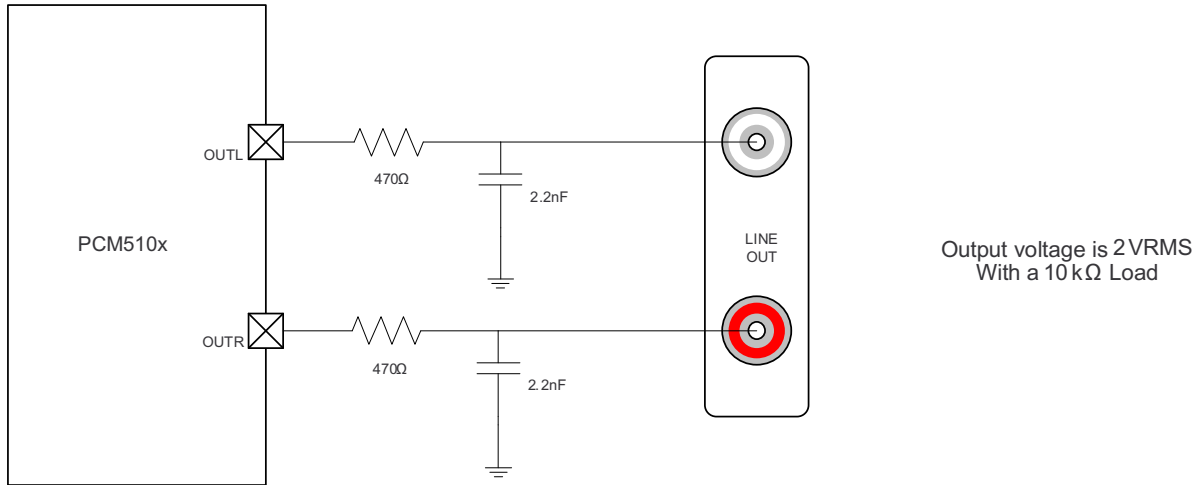

Figure 22. Recommended Output Lowpass Filter for 10kΩ Operation

### Reset and System Clock Functions

#### Power-On Reset Function

The PCM514x includes a power-on reset function shown in [Figure 23](#). With  $V_{DD} > 2.8V$ , the power-on reset function is enabled. After the initialization period, the PCM514x is set to its default reset state.

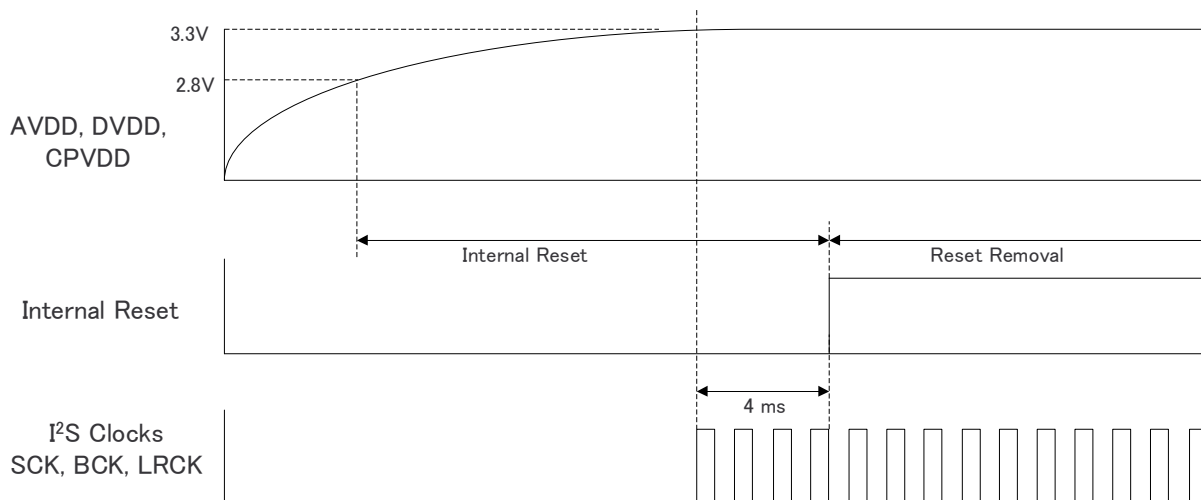

Figure 23. Power-On Reset Timing, DVDD = 3.3V

The PCM514x includes a power-on reset function shown in [Figure 24](#) operating at DVDD=1.8V. With AVDD greater than approximately 2.8V, and PVDD greater than approximately 2.8V, and DVDD greater than approximately 1.5V, the power-on reset function is enabled. After the initialization period, the PCM514x is set to its default reset state.

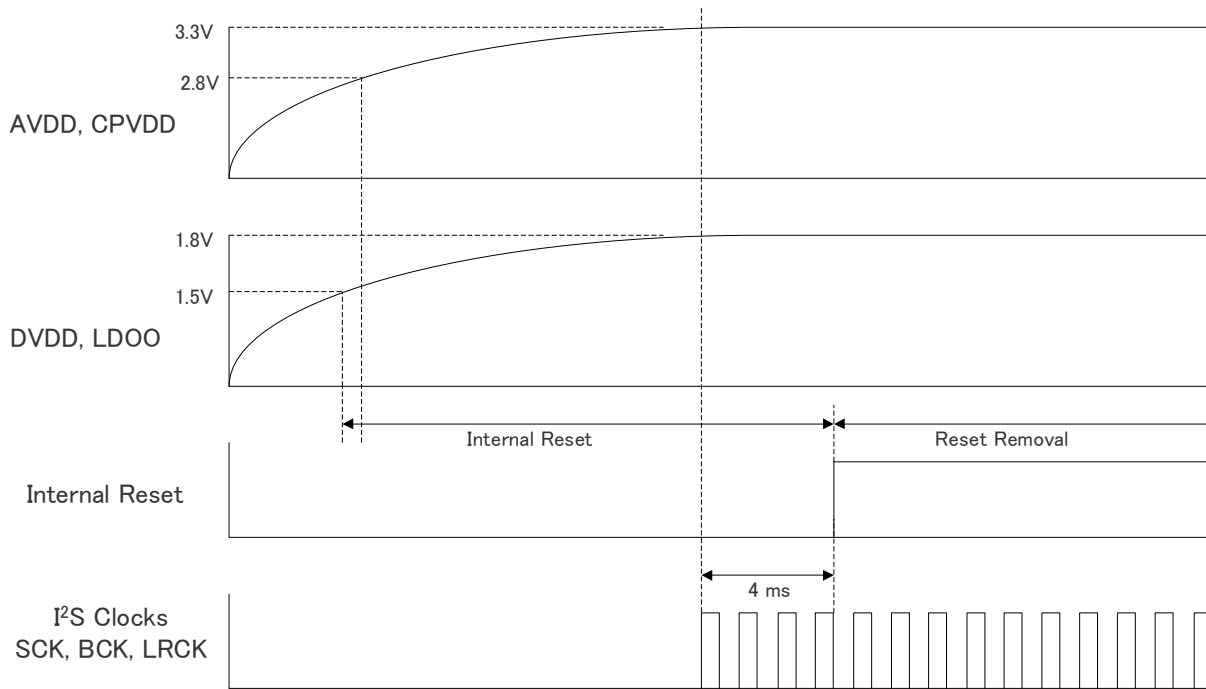

Figure 24. Power-On Reset Timing, DVDD = 1.8V

### System Clock Input

The PCM514x requires a system clock to operate the digital interpolation filters and advanced segment DAC modulators. The system clock is applied at the SCK input (pin 20) and supports up to 50MHz. The PCM514x system-clock detection circuit automatically senses the system-clock frequency. Common audio sampling frequencies of 8kHz, 16kHz, 32kHz - 44.1kHz - 48kHz, 88.2kHz - 96kHz, 176.4kHz -192kHz, and 384kHz with ±4% tolerance are supported. The sampling frequency detector sets the clock for the digital filter, Delta Sigma Modulator (DSM) and the Negative Charge Pump (NCP) automatically. Table 6 shows examples of system clock frequencies for common audio sampling rates.

SCK rates that are not common to standard audio clocks, between 1MHz and 50MHz, are only supported in software mode by configuring various PLL and clock-divider registers. This programmability allows the device to become a clock master and drive the host serial port with LRCK and BCK, from a non-audio related clock (for example, using 12MHz to generate 44.1kHz (LRCK) and 2.8224MHz (BCK) ).

Figure 25 shows the timing requirements for the system clock input. For optimal performance, use a clock source with low phase jitter and noise.

**Table 6. System Master Clock Inputs for Audio Related Clocks**

Sampling Frequency	System Clock Frequency (f <sub>SCK</sub> ) (MHz)											
	64 f <sub>S</sub>	128 f <sub>S</sub>	192 f <sub>S</sub>	256 f <sub>S</sub>	384 f <sub>S</sub>	512 f <sub>S</sub>	768 f <sub>S</sub>	1024 f <sub>S</sub>	1152 f <sub>S</sub>	1536 f <sub>S</sub>	2048 f <sub>S</sub>	3072 f <sub>S</sub>
8 kHz	– <sup>(1)</sup>	1.0240 <sup>(2)</sup>	1.5360 <sup>(2)</sup>	2.0480	3.0720	4.0960	6.1440	8.1920	9.2160	12.2880	16.3840	24.5760
16 kHz	– <sup>(1)</sup>	2.0480 <sup>(2)</sup>	3.0720 <sup>(2)</sup>	4.0960	6.1440	8.1920	12.2880	16.3840	18.4320	24.5760	36.8640	49.1520
32 kHz	– <sup>(1)</sup>	4.0960 <sup>(2)</sup>	6.1440 <sup>(2)</sup>	8.1920	12.2880	16.3840	24.5760	32.7680	36.8640	49.1520	– <sup>(1)</sup>	– <sup>(1)</sup>
44.1 kHz	– <sup>(1)</sup>	5.6488 <sup>(2)</sup>	8.4672 <sup>(2)</sup>	11.2896	16.9344	22.5792	33.8688	45.1584	– <sup>(1)</sup>	– <sup>(1)</sup>	– <sup>(1)</sup>	– <sup>(1)</sup>
48 kHz	– <sup>(1)</sup>	6.1440 <sup>(2)</sup>	9.2160 <sup>(2)</sup>	12.2880	18.4320	24.5760	36.8640	49.1520	– <sup>(1)</sup>	– <sup>(1)</sup>	– <sup>(1)</sup>	– <sup>(1)</sup>
88.2 kHz	– <sup>(1)</sup>	11.2896 <sup>(2)</sup>	16.9344	22.5792	33.8688	45.1584	– <sup>(1)</sup>	– <sup>(1)</sup>	– <sup>(1)</sup>	– <sup>(1)</sup>	– <sup>(1)</sup>	– <sup>(1)</sup>
96 kHz	– <sup>(1)</sup>	12.2880 <sup>(2)</sup>	18.4320	24.5760	36.8640	49.1520	– <sup>(1)</sup>	– <sup>(1)</sup>	– <sup>(1)</sup>	– <sup>(1)</sup>	– <sup>(1)</sup>	– <sup>(1)</sup>
176.4 kHz	– <sup>(1)</sup>	22.5792	33.8688	45.1584	– <sup>(1)</sup>	– <sup>(1)</sup>	– <sup>(1)</sup>	– <sup>(1)</sup>	– <sup>(1)</sup>	– <sup>(1)</sup>	– <sup>(1)</sup>	– <sup>(1)</sup>
192 kHz	– <sup>(1)</sup>	24.5760	36.8640	49.1520	– <sup>(1)</sup>	– <sup>(1)</sup>	– <sup>(1)</sup>	– <sup>(1)</sup>	– <sup>(1)</sup>	– <sup>(1)</sup>	– <sup>(1)</sup>	– <sup>(1)</sup>
384 kHz	24.5760	49.1520	– <sup>(1)</sup>	– <sup>(1)</sup>	– <sup>(1)</sup>	– <sup>(1)</sup>	– <sup>(1)</sup>	– <sup>(1)</sup>	– <sup>(1)</sup>	– <sup>(1)</sup>	– <sup>(1)</sup>	– <sup>(1)</sup>

- (1) This system clock rate is not supported for the given sampling frequency.
- (2) This system clock rate is supported by PLL mode.

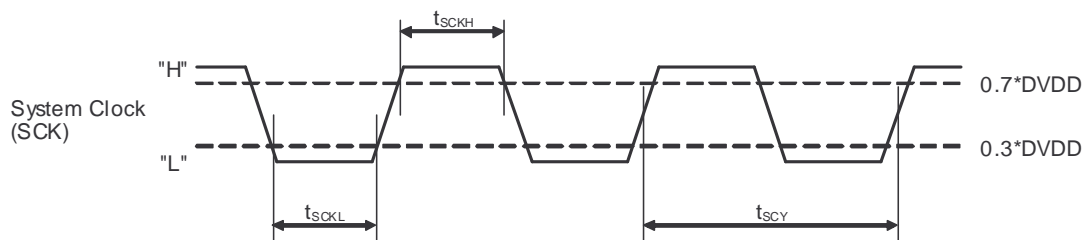

**Figure 25. Timing Requirements for SCK Input**

**Table 7. Timing Requirements for SCK Input**

	Parameters	Min	Max	Unit
t <sub>SCY</sub>	System clock pulse cycle time	20	1000	ns
t <sub>SCKH</sub>	System clock pulse width, High	DVDD=1.8V	8	ns
		DVDD=3.3V	9	
t <sub>SCKL</sub>	System clock pulse width, Low	DVDD=1.8V	8	ns
		DVDD=3.3V	9	

## System Clock PLL Mode

The system clock PLL mode allows designers to use a simple 3-wire I<sup>2</sup>S audio source when driving the DAC. The 3-wire source reduces the need for a high frequency SCK, making PCB layout easier, and reduces high frequency electromagnetic interference.

In hardwired mode, the device starts up expecting an external SCK input, but if BCK and LRCK start correctly while SCK remains at ground level for 16 successive LRCK periods, then the internal PLL starts, automatically generating an internal SCK from the BCK reference. The PCM514x disables the internal PLL when an external SCK is supplied; specific BCK rates are required to generate an appropriate master clock. [Table 8](#) describes the minimum and maximum BCK per LRCK for the integrated PLL to automatically generate an internal SCK.

In hardwired mode, the internal PLL is disabled as soon as an external SCK is supplied; specific BCK rates are required to generate an appropriate master clock. [Table 8](#) lists the minimum and maximum BCK per LRCK for the integrated PLL to automatically generate an internal SCK.

In software mode, the user must set all the PLL registers and clock divider registers for referencing BCK. See [Clock Generation and PLL](#) for more information.

**Table 8. BCK Rates (MHz) by LRCK Sample Rate for PCM514x PLL Operation**

Sample f (kHz)	BCK (f <sub>s</sub> )	
	32	64
8	-	-
16	-	1.024
32	1.024	2.048
44.1	1.4112	2.8224
48	1.536	3.072
96	3.072	6.144
192	6.144	12.288
384	12.288	24.576

## Clock Generation and PLL

The PCM514x supports a wide range of options to generate the required clocks for the DAC section as well as interface and other control blocks as shown in [Figure 26](#).

The clocks for the PLL require a source reference clock. This clock is sourced as the incoming BCK or SCK.

The source reference clock for the PLL reference clock is selected by programming the SRCREF value on Page 0, Register 13, D(6:4). The PLL reference clock can then be routed through highly-flexible clock dividers shown in [Figure 26](#) to generate the various clocks required for the DAC, Negative Charge Pump (NCP), Internal modulator and miniDSP sections. The PCM514x provides several programmable clock dividers to achieve a variety of sampling rates for the DAC and clocks for the NCP, OSR, and the miniDSP. OSRCK for OSR must be set at 16f<sub>s</sub> frequency by DOSR on Page0, Register 30, D(6:0).

If PLL functionality isn't required, set the PLEN value on Page 0, Register 4, D(0) to 0. In this situation, an external SCK is required.

**Table 9. PLL Configuration Registers**

Clock multiplexer	Function	Bits
SRCREF	PLL Reference	Page 0, Register 13, D(6:4)
Divider	Function	Bits
DDSP	miniDSP clock divider	Page 0, Register 27, D(6:0)
DDAC	DAC clock divider	Page 0, Register 28, D(6:0)
DNCP	NCP clock divider	Page 0, Register 29, D(6:0)
DOSR	OSR clock divider	Page 0, Register 30, D(6:0)
DBCK	External BCK Div	Page 0, Register 32, D(6:0)

**Table 9. PLL Configuration Registers (continued)**

DLRK	External LRCK Div	Page 0, Register 33, D(7:0)
------	-------------------	-----------------------------

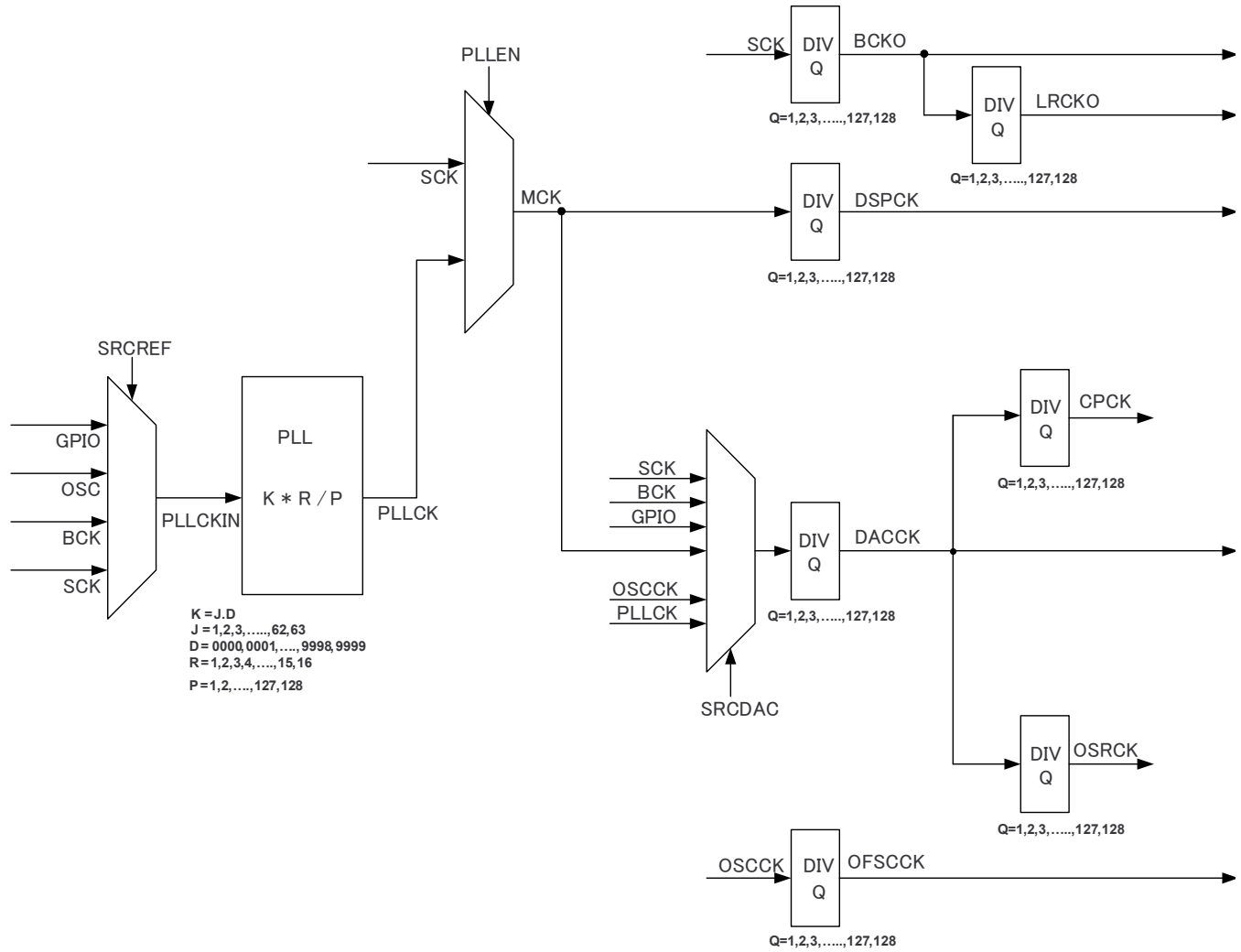

**Figure 26. PLL Clock Source and Clock Distribution**



## PLL Calculation

The PCM514x has an on-chip PLL with fractional multiplication to generate the clock frequency needed by the audio DAC, Negative Charge Pump, Modulator and Digital Signal Processing blocks. The programmability of the PLL allows operation from a wide variety of clocks that may be available in the system. The PLL input (PLLCKIN) supports clock frequencies from 512kHz to 50MHz and is register programmable to enable generation of required sampling rates with fine precision.

The PLL is enabled by default. The PLL can be turned on by writing to Page 0, Register 4, D(0). When the PLL is enabled, the PLL output clock PLLCK is given by [Equation 1](#):

$$\text{PLLCK} = \frac{\text{PLLCKIN} \times R \times J.D}{P} \quad \text{or} \quad \text{PLLCK} = \frac{\text{PLLCKIN} \times R \times K}{P} \quad (1)$$

R = 1, 2, 3, 4, ... , 15, 16

J = 4, 5, 6, . . . 63, and D = 0000, 0001, 0002, . . . 9999

K = [J value].[D value]

P = 1, 2, 3, ... 15

R, J, D, and P are programmable. J is the integer portion of K (the numbers to the left of the decimal point), while D is the fractional portion of K (the numbers to the right of the decimal point, assuming four digits of precision).

### Examples:

- If K = 8.5, then J = 8, D = 5000
- If K = 7.12, then J = 7, D = 1200
- If K = 14.03, then J = 14, D = 0300
- If K = 6.0004, then J = 6, D = 0004

When the PLL is enabled and D = 0000, the following conditions must be satisfied:

- $1\text{MHz} \leq (\text{PLLCKIN} / P) \leq 20\text{MHz}$
- $64\text{MHz} \leq (\text{PLLCKIN} \times K \times R / P) \leq 100\text{MHz}$  (in VREF mode)
- $72\text{MHz} \leq (\text{PLLCKIN} \times K \times R / P) \leq 86\text{MHz}$  (in VCOM mode)
- $1 \leq J \leq 63$

When the PLL is enabled and D ≠ 0000, the following conditions must be satisfied:

- $6.667\text{MHz} \leq \text{PLLCKIN} / P \leq 20\text{MHz}$
- $64\text{MHz} \leq (\text{PLLCKIN} \times K \times R / P) \leq 100\text{MHz}$  (in VREF mode)
- $72\text{MHz} \leq (\text{PLLCKIN} \times K \times R / P) \leq 86\text{MHz}$  (in VCOM mode)
- $4 \leq J \leq 11$
- R = 1

When the PLL is enabled,

- $f_S = (\text{PLLCKIN} \times K \times R) / (2048 \times P)$
- The value of N is selected so that  $f_S \times N = \text{PLLCKIN} \times K \times R / P$  is in the allowable range.

**Example:** MCLK = 12MHz and  $f_S = 44.1\text{kHz}$ , (N=2048)

Select P = 1, R = 1, K = 7.5264, which results in J = 7, D = 5264

**Example:** MCLK = 12MHz and  $f_S = 48.0\text{kHz}$ , (N=2048)

Select P = 1, R = 1, K = 8.192, which results in J = 8, D = 1920

Values are written to the registers in [Table 10](#).

**Table 10. PLL Registers**

Divider	Function	Bits
PLLE	PLL enable	Page 0, Register 4, D(0)
PPDV	PLL P	Page 0, Register 20, D(3:0)
PJDV	PLL J	Page 0, Register 21, D(5:0)
PDDV	PLL D	Page 0, Register 22, D(5:0)
		Page 0, Register 23, D(7:0)
PRDV	PLL R	Page 0, Register 24, D(3:0)

**Table 11. PLL Configuration Recommendations**

Column	Description
$f_s$ (kHz)	Sampling frequency
RSCK	Ratio between sampling frequency and SCK frequency (SCK frequency = RSCK x sampling frequency)
SCK (MHz)	System master clock frequency at SCK input (pin 20)
PLL VCO (MHz)	PLL VCO frequency as PLLCK in <a href="#">Figure 26</a>
P	One of the PLL coefficients in <a href="#">Equation 1</a>
PLL REF (MHz)	Internal reference clock frequency which is produced by SCK / P
$M = K * R$	The final PLL multiplication factor computed from K and R as described in <a href="#">Equation 1</a>
$K = J.D$	One of the PLL coefficients in <a href="#">Equation 1</a>
R	One of the PLL coefficients in <a href="#">Equation 1</a>
PLL $f_s$	Ratio between $f_s$ and PLL VCO frequency (PLL VCO / $f_s$ )
DSP $f_s$	Ratio between miniDSP operating clock rate and $f_s$ (PLL $f_s$ / NMAC)
NMAC	The miniDSP clock divider value in <a href="#">Table 9</a>
DSP CLK (MHz)	The miniDSP operating frequency as DSPCK in <a href="#">Figure 26</a>
MOD $f_s$	Ratio between DAC operating clock frequency and $f_s$ (PLL $f_s$ / NDAC)
MOD f (kHz)	DAC operating frequency as DACCK in <a href="#">Figure 26</a>
NDAC	DAC clock divider value in <a href="#">Table 9</a>
DOSR	OSR clock divider value in <a href="#">Table 9</a> for generating OSRCK in <a href="#">Figure 26</a> . DOSR must be chosen so that MOD $f_s$ / DOSR = 16 for correct operation.
NCP	NCP (negative charge pump) clock divider value in <a href="#">Table 9</a>
CP f	Negative charge pump clock frequency ( $f_s * \text{MOD } f_s / \text{NCP}$ )
% Error	Percentage of error between PLL VCO / PLL $f_s$ and $f_s$ (mismatch error). <ul style="list-style-type: none"> <li>This number is typically zero but can be non-zero especially when K is not an integer (D is not zero).</li> <li>This number may be non-zero only when the PCM514xacts as a master.</li> </ul>

**Table 12. Recommended Clock Divider Settings for PLL as Master Clock (VREF Mode)**

f <sub>s</sub> (kHz)	RSCK	SCK (MHz)	PLL VCO (MHz)	P	PLL REF (MHz)	M = K*R	K = J.D	R	PLL f <sub>s</sub>	DSP f <sub>s</sub>	NMAC	DSP CLK (MHz)	MOD f <sub>s</sub>	MOD f (kHz)	NDAC	DOSR	% Error	NCP	CP f (kHz)
8	128	1.024	98.304	1	1.024	96	48	2	12288	1024	12	8.192	768	6144	16	48	0	4	1536
8	192	1.536	98.304	1	1.536	64	32	2	12288	1024	12	8.192	768	6144	16	48	0	4	1536
8	256	2.048	98.304	1	2.048	48	48	1	12288	1024	12	8.192	768	6144	16	48	0	4	1536
8	384	3.072	98.304	3	1.024	96	48	2	12288	1024	12	8.192	768	6144	16	48	0	4	1536
8	512	4.096	98.304	3	1.365	72	36	2	12288	1024	12	8.192	768	6144	16	48	0	4	1536
8	768	6.144	98.304	3	2.048	48	48	1	12288	1024	12	8.192	768	6144	16	48	0	4	1536
8	1024	8.192	98.304	3	2.731	36	36	1	12288	1024	12	8.192	768	6144	16	48	0	4	1536
8	1152	9.216	98.304	9	1.024	96	48	2	12288	1024	12	8.192	768	6144	16	48	0	4	1536
8	1536	12.288	98.304	9	1.365	72	36	2	12288	1024	12	8.192	768	6144	16	48	0	4	1536
8	2048	16.384	98.304	9	1.82	54	54	1	12288	1024	12	8.192	768	6144	16	48	0	4	1536
8	3072	24.576	98.304	9	2.731	36	36	1	12288	1024	12	8.192	768	6144	16	48	0	4	1536
11.025	128	1.4112	90.3168	1	1.411	64	32	2	8192	1024	8	11.2896	512	5644.8	16	32	0	4	1411.2
11.025	192	2.1168	90.3168	3	0.706	128	32	4	8192	1024	8	11.2896	512	5644.8	16	32	0	4	1411.2
11.025	256	2.8224	90.3168	1	2.822	32	32	1	8192	1024	8	11.2896	512	5644.8	16	32	0	4	1411.2
11.025	384	4.2336	90.3168	3	1.411	64	32	2	8192	1024	8	11.2896	512	5644.8	16	32	0	4	1411.2
11.025	512	5.6448	90.3168	3	1.882	48	48	1	8192	1024	8	11.2896	512	5644.8	16	32	0	4	1411.2
11.025	768	8.4672	90.3168	3	2.822	32	32	1	8192	1024	8	11.2896	512	5644.8	16	32	0	4	1411.2
11.025	1024	11.2896	90.3168	3	3.763	24	24	1	8192	1024	8	11.2896	512	5644.8	16	32	0	4	1411.2
11.025	1152	12.7008	90.3168	9	1.411	64	32	2	8192	1024	8	11.2896	512	5644.8	16	32	0	4	1411.2
11.025	1536	16.9344	90.3168	9	1.882	48	48	1	8192	1024	8	11.2896	512	5644.8	16	32	0	4	1411.2
11.025	2048	22.5792	90.3168	9	2.509	36	36	1	8192	1024	8	11.2896	512	5644.8	16	32	0	4	1411.2
11.025	3072	33.8688	90.3168	9	3.763	24	24	1	8192	1024	8	11.2896	512	5644.8	16	32	0	4	1411.2
16	64	1.024	98.304	1	1.024	96	48	2	6144	1024	6	16.384	384	6144	16	24	0	4	1536
16	128	2.048	98.304	1	2.048	48	48	1	6144	1024	6	16.384	384	6144	16	24	0	4	1536
16	192	3.072	98.304	1	3.072	32	32	1	6144	1024	6	16.384	384	6144	16	24	0	4	1536
16	256	4.096	98.304	1	4.096	24	24	1	6144	1024	6	16.384	384	6144	16	24	0	4	1536
16	384	6.144	98.304	3	2.048	48	48	1	6144	1024	6	16.384	384	6144	16	24	0	4	1536
16	512	8.192	98.304	3	2.731	36	36	1	6144	1024	6	16.384	384	6144	16	24	0	4	1536
16	768	12.288	98.304	3	4.096	24	24	1	6144	1024	6	16.384	384	6144	16	24	0	4	1536
16	1024	16.384	98.304	3	5.461	18	18	1	6144	1024	6	16.384	384	6144	16	24	0	4	1536
16	1152	18.432	98.304	3	6.144	16	16	1	6144	1024	6	16.384	384	6144	16	24	0	4	1536
16	1536	24.576	98.304	9	2.731	36	36	1	6144	1024	6	16.384	384	6144	16	24	0	4	1536
16	2048	32.768	98.304	9	3.641	27	27	1	6144	1024	6	16.384	384	6144	16	24	0	4	1536
16	3072	49.152	98.304	9	5.461	18	18	1	6144	1024	6	16.384	384	6144	16	24	0	4	1536
22.05	64	1.4112	90.3168	1	1.411	64	32	2	4096	1024	4	22.5792	256	5644.8	16	16	0	4	1411.2
22.05	128	2.8224	90.3168	1	2.822	32	32	1	4096	1024	4	22.5792	256	5644.8	16	16	0	4	1411.2
22.05	192	4.2336	90.3168	3	1.411	64	32	2	4096	1024	4	22.5792	256	5644.8	16	16	0	4	1411.2
22.05	256	5.6448	90.3168	1	5.645	16	16	1	4096	1024	4	22.5792	256	5644.8	16	16	0	4	1411.2

**Table 12. Recommended Clock Divider Settings for PLL as Master Clock (VREF Mode) (continued)**

f <sub>s</sub> (kHz)	RSCK	SCK (MHz)	PLL VCO (MHz)	P	PLL REF (MHz)	M = K*R	K = J.D	R	PLL f <sub>s</sub>	DSP f <sub>s</sub>	NMAC	DSP CLK (MHz)	MOD f <sub>s</sub>	MOD f (kHz)	NDAC	DOSR	% Error	NCP	CP f (kHz)
22.05	384	8.4672	90.3168	3	2.822	32	32	1	4096	1024	4	22.5792	256	5644.8	16	16	0	4	1411.2
22.05	512	11.2896	90.3168	3	3.763	24	24	1	4096	1024	4	22.5792	256	5644.8	16	16	0	4	1411.2
22.05	768	16.9344	90.3168	3	5.645	16	16	1	4096	1024	4	22.5792	256	5644.8	16	16	0	4	1411.2
22.05	1024	22.5792	90.3168	3	7.526	12	12	1	4096	1024	4	22.5792	256	5644.8	16	16	0	4	1411.2
22.05	1152	25.4016	90.3168	9	2.822	32	32	1	4096	1024	4	22.5792	256	5644.8	16	16	0	4	1411.2
22.05	1536	33.8688	90.3168	9	3.763	24	24	1	4096	1024	4	22.5792	256	5644.8	16	16	0	4	1411.2
22.05	2048	45.1584	90.3168	9	5.018	18	18	1	4096	1024	4	22.5792	256	5644.8	16	16	0	4	1411.2
32	32	1.024	98.304	1	1.024	96	48	2	3072	1024	3	32.768	192	6144	16	12	0	4	1536
32	48	1.536	98.304	1	1.536	64	16	4	3072	1024	3	32.768	192	6144	16	12	0	4	1536
32	64	2.048	98.304	1	2.048	48	24	2	3072	1024	3	32.768	192	6144	16	12	0	4	1536
32	128	4.096	98.304	1	4.096	24	24	1	3072	1024	3	32.768	192	6144	16	12	0	4	1536
32	192	6.144	98.304	3	2.048	48	48	1	3072	1024	3	32.768	192	6144	16	12	0	4	1536
32	256	8.192	98.304	2	4.096	24	24	1	3072	1024	3	32.768	192	6144	16	12	0	4	1536
32	384	12.288	98.304	3	4.096	24	24	1	3072	1024	3	32.768	192	6144	16	12	0	4	1536
32	512	16.384	98.304	3	5.461	18	18	1	3072	1024	3	32.768	192	6144	16	12	0	4	1536
32	768	24.576	98.304	3	8.192	12	12	1	3072	1024	3	32.768	192	6144	16	12	0	4	1536
32	1024	32.768	98.304	3	10.923	9	9	1	3072	1024	3	32.768	192	6144	16	12	0	4	1536
32	1152	36.864	98.304	9	4.096	24	24	1	3072	1024	3	32.768	192	6144	16	12	0	4	1536
32	1536	49.152	98.304	6	8.192	12	12	1	3072	1024	3	32.768	192	6144	16	12	0	4	1536
44.1	32	1.4112	90.3168	1	1.411	64	32	2	2048	1024	2	45.1584	128	5644.8	16	8	0	4	1411.2
44.1	64	2.8224	90.3168	1	2.822	32	16	2	2048	1024	2	45.1584	128	5644.8	16	8	0	4	1411.2
44.1	128	5.6448	90.3168	1	5.645	16	16	1	2048	1024	2	45.1584	128	5644.8	16	8	0	4	1411.2
44.1	192	8.4672	90.3168	3	2.822	32	32	1	2048	1024	2	45.1584	128	5644.8	16	8	0	4	1411.2
44.1	256	11.2896	90.3168	2	5.645	16	16	1	2048	1024	2	45.1584	128	5644.8	16	8	0	4	1411.2
44.1	384	16.9344	90.3168	3	5.645	16	16	1	2048	1024	2	45.1584	128	5644.8	16	8	0	4	1411.2
44.1	512	22.5792	90.3168	3	7.526	12	12	1	2048	1024	2	45.1584	128	5644.8	16	8	0	4	1411.2
44.1	768	33.8688	90.3168	3	11.29	8	8	1	2048	1024	2	45.1584	128	5644.8	16	8	0	4	1411.2
44.1	1024	45.1584	90.3168	3	15.053	6	6	1	2048	1024	2	45.1584	128	5644.8	16	8	0	4	1411.2
48	32	1.536	98.304	1	1.536	64	32	2	2048	1024	2	49.152	128	6144	16	8	0	4	1536
48	64	3.072	98.304	1	3.072	32	16	2	2048	1024	2	49.152	128	6144	16	8	0	4	1536
48	128	6.144	98.304	1	6.144	16	16	1	2048	1024	2	49.152	128	6144	16	8	0	4	1536
48	192	9.216	98.304	3	3.072	32	32	1	2048	1024	2	49.152	128	6144	16	8	0	4	1536
48	256	12.288	98.304	2	6.144	16	16	1	2048	1024	2	49.152	128	6144	16	8	0	4	1536
48	384	18.432	98.304	3	6.144	16	16	1	2048	1024	2	49.152	128	6144	16	8	0	4	1536
48	512	24.576	98.304	3	8.192	12	12	1	2048	1024	2	49.152	128	6144	16	8	0	4	1536
48	768	36.864	98.304	3	12.288	8	8	1	2048	1024	2	49.152	128	6144	16	8	0	4	1536
48	1024	49.152	98.304	3	16.384	6	6	1	2048	1024	2	49.152	128	6144	16	8	0	4	1536
96	32	3.072	98.304	1	3.072	32	16	2	1024	512	2	49.152	64	6144	16	4	0	4	1536

**Table 12. Recommended Clock Divider Settings for PLL as Master Clock (VREF Mode) (continued)**

f <sub>s</sub> (kHz)	RSCK	SCK (MHz)	PLL VCO (MHz)	P	PLL REF (MHz)	M = K*R	K = J.D	R	PLL f <sub>s</sub>	DSP f <sub>s</sub>	NMAC	DSP CLK (MHz)	MOD f <sub>s</sub>	MOD f (kHz)	NDAC	DOSR	% Error	NCP	CP f (kHz)
96	48	4.608	98.304	3	1.536	64	32	2	1024	512	2	49.152	64	6144	16	4	0	4	1536
96	64	6.144	98.304	1	6.144	16	8	2	1024	512	2	49.152	64	6144	16	4	0	4	1536
96	128	12.288	98.304	2	6.144	16	16	1	1024	512	2	49.152	64	6144	16	4	0	4	1536
96	192	18.432	98.304	3	6.144	16	16	1	1024	512	2	49.152	64	6144	16	4	0	4	1536
96	256	24.576	98.304	4	6.144	16	16	1	1024	512	2	49.152	64	6144	16	4	0	4	1536
96	384	36.864	98.304	6	6.144	16	16	1	1024	512	2	49.152	64	6144	16	4	0	4	1536
96	512	49.152	98.304	8	6.144	16	16	1	1024	512	2	49.152	64	6144	16	4	0	4	1536
192	32	6.144	98.304	1	6.144	16	8	2	512	256	2	49.152	32	6144	16	2	0	4	1536
192	48	9.216	98.304	3	3.072	32	16	2	512	256	2	49.152	32	6144	16	2	0	4	1536
192	64	12.288	98.304	1	12.288	8	4	2	512	256	2	49.152	32	6144	16	2	0	4	1536
192	128	24.576	98.304	2	12.288	8	8	1	512	256	2	49.152	32	6144	16	2	0	4	1536
192	192	36.864	98.304	3	12.288	8	8	1	512	256	2	49.152	32	6144	16	2	0	4	1536
192	256	49.152	98.304	4	12.288	8	8	1	512	256	2	49.152	32	6144	16	2	0	4	1536
384	32	12.288	98.304	2	6.144	16	8	2	256	128	2	49.152	16	6144	16	1	0	4	1536
384	48	18.432	98.304	3	6.144	16	8	2	256	128	2	49.152	16	6144	16	1	0	4	1536
384	64	24.576	98.304	2	12.288	8	4	2	256	128	2	49.152	16	6144	16	1	0	4	1536
384	128	49.152	98.304	4	12.288	8	8	1	256	128	2	49.152	16	6144	16	1	0	4	1536

**Table 13. Recommended Clock Divider Settings for PLL as Master Clock (VCOM Mode)**

f <sub>s</sub> (kHz)	RSCK	SCK (MHz)	PLL VCO (MHz)	P	PLL REF (MHz)	M = K*R	K = J.D	R	PLL FS	DSP FS	NMAC	DSP CLK (MHz)	MOD f <sub>s</sub>	MOD f (kHz)	NDAC	DOSR	% Error	NCP	CP f (kHz)
8	128	1.024	73.728	1	1.024	72	36	2	9216	768	12	6.144	768	6144	12	48	0	4	1536
8	192	1.536	73.728	1	1.536	48	24	2	9216	768	12	6.144	768	6144	12	48	0	4	1536
8	256	2.048	73.728	1	2.048	36	36	1	9216	768	12	6.144	768	6144	12	48	0	4	1536
8	384	3.072	73.728	1	3.072	24	12	2	9216	768	12	6.144	768	6144	12	48	0	4	1536
8	512	4.096	73.728	2	2.048	36	36	1	9216	768	12	6.144	768	6144	12	48	0	4	1536
8	768	6.144	73.728	3	2.048	36	36	1	9216	768	12	6.144	768	6144	12	48	0	4	1536
8	1024	8.192	73.728	4	2.048	36	36	1	9216	768	12	6.144	768	6144	12	48	0	4	1536
8	1152	9.216	73.728	6	1.536	48	48	1	9216	768	12	6.144	768	6144	12	48	0	4	1536
8	1536	12.288	73.728	6	2.048	36	36	1	9216	768	12	6.144	768	6144	12	48	0	4	1536
8	2048	16.384	73.728	8	2.048	36	36	1	9216	768	12	6.144	768	6144	12	48	0	4	1536
8	3072	24.576	73.728	12	2.048	36	36	1	9216	768	12	6.144	768	6144	12	48	0	4	1536
11.025	128	1.4112	84.672	1	1.411	60	30	2	7680	960	8	10.584	512	5644.8	15	32	0	4	1411.2
11.025	192	2.1168	84.672	1	2.117	40	10	4	7680	960	8	10.584	512	5644.8	15	32	0	4	1411.2
11.025	256	2.8224	84.672	1	2.822	30	30	1	7680	960	8	10.584	512	5644.8	15	32	0	4	1411.2
11.025	384	4.2336	84.672	2	2.117	40	20	2	7680	960	8	10.584	512	5644.8	15	32	0	4	1411.2
11.025	512	5.6448	84.672	2	2.822	30	30	1	7680	960	8	10.584	512	5644.8	15	32	0	4	1411.2
11.025	768	8.4672	84.672	3	2.822	30	30	1	7680	960	8	10.584	512	5644.8	15	32	0	4	1411.2
11.025	1024	11.2896	84.672	4	2.822	30	30	1	7680	960	8	10.584	512	5644.8	15	32	0	4	1411.2
11.025	1152	12.7008	84.672	6	2.117	40	20	2	7680	960	8	10.584	512	5644.8	15	32	0	4	1411.2
11.025	1536	16.9344	84.672	8	2.117	40	40	1	7680	960	8	10.584	512	5644.8	15	32	0	4	1411.2
11.025	2048	22.5792	84.672	8	2.822	30	30	1	7680	960	8	10.584	512	5644.8	15	32	0	4	1411.2
11.025	3072	33.8688	84.672	8	4.234	20	20	1	7680	960	8	10.584	512	5644.8	15	32	0	4	1411.2
16	64	1.024	73.728	1	1.024	72	36	2	4608	768	6	12.288	384	6144	12	24	0	4	1536
16	128	2.048	73.728	1	2.048	36	36	1	4608	768	6	12.288	384	6144	12	24	0	4	1536
16	192	3.072	73.728	1	3.072	24	24	1	4608	768	6	12.288	384	6144	12	24	0	4	1536
16	256	4.096	73.728	2	2.048	36	36	1	4608	768	6	12.288	384	6144	12	24	0	4	1536
16	384	6.144	73.728	3	2.048	36	36	1	4608	768	6	12.288	384	6144	12	24	0	4	1536
16	512	8.192	73.728	4	2.048	36	36	1	4608	768	6	12.288	384	6144	12	24	0	4	1536
16	768	12.288	73.728	6	2.048	36	36	1	4608	768	6	12.288	384	6144	12	24	0	4	1536
16	1024	16.384	73.728	8	2.048	36	36	1	4608	768	6	12.288	384	6144	12	24	0	4	1536
16	1152	18.432	73.728	9	2.048	36	36	1	4608	768	6	12.288	384	6144	12	24	0	4	1536
16	1536	24.576	73.728	8	3.072	24	24	1	4608	768	6	12.288	384	6144	12	24	0	4	1536
16	2048	32.768	73.728	8	4.096	18	18	1	4608	768	6	12.288	384	6144	12	24	0	4	1536
16	3072	49.152	73.728	8	6.144	12	12	1	4608	768	6	12.288	384	6144	12	24	0	4	1536
22.05	64	1.4112	84.672	1	1.411	60	30	2	3840	960	4	21.168	256	5644.8	15	16	0	4	1411.2
22.05	128	2.8224	84.672	1	2.822	30	30	1	3840	960	4	21.168	256	5644.8	15	16	0	4	1411.2
22.05	192	4.2336	84.672	3	1.411	60	30	2	3840	960	4	21.168	256	5644.8	15	16	0	4	1411.2
22.05	256	5.6448	84.672	2	2.822	30	30	1	3840	960	4	21.168	256	5644.8	15	16	0	4	1411.2

**Table 13. Recommended Clock Divider Settings for PLL as Master Clock (VCOM Mode) (continued)**

f <sub>s</sub> (kHz)	RSCK	SCK (MHz)	PLL VCO (MHz)	P	PLL REF (MHz)	M = K*R	K = J.D	R	PLL FS	DSP FS	NMAC	DSP CLK (MHz)	MOD f <sub>s</sub>	MOD f (kHz)	NDAC	DOSR	% Error	NCP	CP f (kHz)
22.05	384	8.4672	84.672	3	2.822	30	30	1	3840	960	4	21.168	256	5644.8	15	16	0	4	1411.2
22.05	512	11.2896	84.672	2	5.645	15	15	1	3840	960	4	21.168	256	5644.8	15	16	0	4	1411.2
22.05	768	16.9344	84.672	3	5.645	15	15	1	3840	960	4	21.168	256	5644.8	15	16	0	4	1411.2
22.05	1024	22.5792	84.672	4	5.645	15	15	1	3840	960	4	21.168	256	5644.8	15	16	0	4	1411.2
22.05	1152	25.4016	84.672	9	2.822	30	30	1	3840	960	4	21.168	256	5644.8	15	16	0	4	1411.2
22.05	1536	33.8688	84.672	8	4.234	20	20	1	3840	960	4	21.168	256	5644.8	15	16	0	4	1411.2
22.05	2048	45.1584	84.672	8	5.645	15	15	1	3840	960	4	21.168	256	5644.8	15	16	0	4	1411.2
32	32	1.024	73.728	1	1.024	72	36	2	2304	768	3	24.576	192	6144	12	12	0	4	1536
32	48	1.536	73.728	1	1.536	48	12	4	2304	768	3	24.576	192	6144	12	12	0	4	1536
32	64	2.048	73.728	1	2.048	36	18	2	2304	768	3	24.576	192	6144	12	12	0	4	1536
32	128	4.096	73.728	2	2.048	36	36	1	2304	768	3	24.576	192	6144	12	12	0	4	1536
32	192	6.144	73.728	3	2.048	36	36	1	2304	768	3	24.576	192	6144	12	12	0	4	1536
32	256	8.192	73.728	4	2.048	36	36	1	2304	768	3	24.576	192	6144	12	12	0	4	1536
32	384	12.288	73.728	6	2.048	36	36	1	2304	768	3	24.576	192	6144	12	12	0	4	1536
32	512	16.384	73.728	8	2.048	36	36	1	2304	768	3	24.576	192	6144	12	12	0	4	1536
32	768	24.576	73.728	6	4.096	18	18	1	2304	768	3	24.576	192	6144	12	12	0	4	1536
32	1024	32.768	73.728	8	4.096	18	18	1	2304	768	3	24.576	192	6144	12	12	0	4	1536
32	1152	36.864	73.728	9	4.096	18	18	1	2304	768	3	24.576	192	6144	12	12	0	4	1536
32	1536	49.152	73.728	12	4.096	18	18	1	2304	768	3	24.576	192	6144	12	12	0	4	1536
44.1	32	1.4112	84.672	1	1.411	60	30	2	1920	960	2	42.336	128	5644.8	15	8	0	4	1411.2
44.1	48	2.1168	84.672	1	2.117	40	10	4	1920	960	2	42.336	128	5644.8	15	8	0	4	1411.2
44.1	64	2.8224	84.672	1	2.822	30	15	2	1920	960	2	42.336	128	5644.8	15	8	0	4	1411.2
44.1	128	5.6448	84.672	1	5.645	15	15	1	1920	960	2	42.336	128	5644.8	15	8	0	4	1411.2
44.1	192	8.4672	84.672	2	4.234	20	20	1	1920	960	2	42.336	128	5644.8	15	8	0	4	1411.2
44.1	256	11.2896	84.672	2	5.645	15	15	1	1920	960	2	42.336	128	5644.8	15	8	0	4	1411.2
44.1	384	16.9344	84.672	3	5.645	15	15	1	1920	960	2	42.336	128	5644.8	15	8	0	4	1411.2
44.1	512	22.5792	84.672	4	5.645	15	15	1	1920	960	2	42.336	128	5644.8	15	8	0	4	1411.2
44.1	768	33.8688	84.672	6	5.645	15	15	1	1920	960	2	42.336	128	5644.8	15	8	0	4	1411.2
44.1	1024	45.1584	84.672	8	5.645	15	15	1	1920	960	2	42.336	128	5644.8	15	8	0	4	1411.2
48	32	1.536	73.728	1	1.536	48	24	2	1536	768	2	36.864	128	6144	12	8	0	4	1536
48	48	2.304	73.728	1	2.304	32	8	4	1536	768	2	36.864	128	6144	12	8	0	4	1536
48	64	3.072	73.728	1	3.072	24	12	2	1536	768	2	36.864	128	6144	12	8	0	4	1536
48	128	6.144	73.728	2	3.072	24	24	1	1536	768	2	36.864	128	6144	12	8	0	4	1536
48	192	9.216	73.728	3	3.072	24	24	1	1536	768	2	36.864	128	6144	12	8	0	4	1536
48	256	12.288	73.728	4	3.072	24	24	1	1536	768	2	36.864	128	6144	12	8	0	4	1536
48	384	18.432	73.728	6	3.072	24	24	1	1536	768	2	36.864	128	6144	12	8	0	4	1536
48	512	24.576	73.728	4	6.144	12	12	1	1536	768	2	36.864	128	6144	12	8	0	4	1536
48	768	36.864	73.728	6	6.144	12	12	1	1536	768	2	36.864	128	6144	12	8	0	4	1536

**Table 13. Recommended Clock Divider Settings for PLL as Master Clock (VCOM Mode) (continued)**

$f_s$ (kHz)	RSCK	SCK (MHz)	PLL VCO (MHz)	P	PLL REF (MHz)	M = K*R	K = J.D	R	PLL FS	DSP FS	NMAC	DSP CLK (MHz)	MOD $f_s$	MOD f (kHz)	NDAC	DOSR	% Error	NCP	CP f (kHz)
48	1024	49.152	73.728	8	6.144	12	12	1	1536	768	2	36.864	128	6144	12	8	0	4	1536
96	32	3.072	73.728	2	1.536	48	24	2	768	384	2	36.864	64	6144	12	4	0	4	1536
96	48	4.608	73.728	3	1.536	48	24	2	768	384	2	36.864	64	6144	12	4	0	4	1536
96	64	6.144	73.728	2	3.072	24	12	2	768	384	2	36.864	64	6144	12	4	0	4	1536
96	128	12.288	73.728	4	3.072	24	24	1	768	384	2	36.864	64	6144	12	4	0	4	1536
96	192	18.432	73.728	6	3.072	24	24	1	768	384	2	36.864	64	6144	12	4	0	4	1536
96	256	24.576	73.728	8	3.072	24	24	1	768	384	2	36.864	64	6144	12	4	0	4	1536
96	384	36.864	73.728	6	6.144	12	12	1	768	384	2	36.864	64	6144	12	4	0	4	1536
96	512	49.152	73.728	8	6.144	12	12	1	768	384	2	36.864	64	6144	12	4	0	4	1536
192	32	6.144	73.728	2	3.072	24	12	2	384	192	2	36.864	32	6144	12	2	0	4	1536
192	48	9.216	73.728	3	3.072	24	12	2	384	192	2	36.864	32	6144	12	2	0	4	1536
192	64	12.288	73.728	4	3.072	24	12	2	384	192	2	36.864	32	6144	12	2	0	4	1536
192	128	24.576	73.728	8	3.072	24	24	1	384	192	2	36.864	32	6144	12	2	0	4	1536
192	192	36.864	73.728	6	6.144	12	12	1	384	192	2	36.864	32	6144	12	2	0	4	1536
192	256	49.152	73.728	8	6.144	12	12	1	384	192	2	36.864	32	6144	12	2	0	4	1536
384	32	12.288	73.728	2	6.144	12	6	2	192	96	2	36.864	16	6144	12	1	0	4	1536
384	48	18.432	73.728	3	6.144	12	6	2	192	96	2	36.864	16	6144	12	1	0	4	1536
384	64	24.576	73.728	4	6.144	12	6	2	192	96	2	36.864	16	6144	12	1	0	4	1536
384	128	49.152	73.728	8	6.144	12	12	1	192	96	2	36.864	16	6144	12	1	0	4	1536



**Table 14. Recommended Clock Divider Settings for SCK as Master Clock**

$f_s$ (kHz)	RSCK	SCK (MHz)	DSP $f_s$	NMAC	DSP CLK (MHz)	MOD $f_s$	MOD f (kHz)	NDAC	DOSR	NCP	CP f (kHz)
8	256	2.048	256	1	2.048	256	2048	1	16	2	1024
8	384	3.072	384	1	3.072	384	3072	1	24	2	1536
8	512	4.096	512	1	4.096	512	4096	1	32	2	2048
8	768	6.144	768	1	6.144	768	6144	1	48	4	1536
8	1024	8.192	1024	1	8.192	512	4096	2	32	2	2048
8	1152	9.216	1152	1	9.216	576	4608	2	36	4	1152
8	1536	12.288	1536	1	12.288	768	6144	2	48	4	1536
8	2048	16.384	2048	1	16.384	512	4096	4	32	2	2048
8	3072	24.576	3072	1	24.576	768	6144	4	48	4	1536
11.025	256	2.8224	256	1	2.822	256	2822.4	1	16	2	1411.2
11.025	384	4.2336	384	1	4.234	384	4233.6	1	24	4	1058.4
11.025	1152	12.7008	1152	1	12.701	384	4233.6	3	24	4	1058.4
11.025	1536	16.9344	1536	1	16.934	512	5644.8	3	32	4	1411.2
11.025	2048	22.5792	2048	1	22.579	512	5644.8	4	32	4	1411.2
11.025	3072	33.8688	3072	1	33.869	512	5644.8	6	32	4	1411.2
16	256	4.096	256	1	4.096	256	4096	1	16	2	2048
16	384	6.144	384	1	6.144	384	6144	1	24	4	1536
16	512	8.192	512	1	8.192	256	4096	2	16	2	2048
16	768	12.288	768	1	12.288	384	6144	2	24	4	1536
16	1152	18.432	1152	1	18.432	288	4608	4	18	4	1152
16	1536	24.576	1536	1	24.576	384	6144	4	24	4	1536
16	2048	32.768	2048	1	32.768	256	4096	8	16	2	2048
16	3072	49.152	3072	1	49.152	384	6144	8	24	4	1536
22.05	256	5.6448	256	1	5.645	256	5644.8	1	16	4	1411.2
22.05	384	8.4672	384	1	8.467	192	4233.6	2	12	4	1058.4
22.05	512	11.2896	512	1	11.29	256	5644.8	2	16	4	1411.2
22.05	768	16.9344	768	1	16.934	256	5644.8	3	16	4	1411.2
22.05	1024	22.5792	1024	1	22.579	256	5644.8	4	16	4	1411.2
22.05	1152	25.4016	1152	1	25.402	192	4233.6	6	12	4	1058.4
22.05	1536	33.8688	1536	1	33.869	256	5644.8	6	16	4	1411.2
22.05	2048	45.1584	2048	1	45.158	256	5644.8	8	16	4	1411.2
32	256	8.192	256	1	8.192	128	4096	2	8	2	2048
32	384	12.288	384	1	12.288	128	4096	3	8	2	2048
32	512	16.384	512	1	16.384	128	4096	4	8	2	2048
32	768	24.576	768	1	24.576	128	4096	6	8	2	2048
32	1024	32.768	1024	1	32.768	128	4096	8	8	2	2048
32	1152	36.864	1152	1	36.864	128	4096	9	8	4	1024
32	1536	49.152	1536	1	49.152	128	4096	12	8	4	1024
44.1	256	11.2896	256	1	11.29	128	5644.8	2	8	4	1411.2
44.1	384	16.9344	384	1	16.934	128	5644.8	3	8	4	1411.2
44.1	512	22.5792	512	1	22.579	128	5644.8	4	8	4	1411.2
44.1	768	33.8688	768	1	33.869	128	5644.8	6	8	4	1411.2
44.1	1024	45.1584	1024	1	45.158	128	5644.8	8	8	4	1411.2
48	256	12.288	256	1	12.288	128	6144	2	8	4	1536
48	384	18.432	384	1	18.432	128	6144	3	8	4	1536
48	512	24.576	512	1	24.576	128	6144	4	8	4	1536
48	768	36.864	768	1	36.864	128	6144	6	8	4	1536
48	1024	49.152	1024	1	49.152	128	6144	8	8	4	1536
96	192	18.432	192	1	18.432	48	4608	4	3	6	768
96	256	24.576	256	1	24.576	64	6144	4	4	4	1536
96	384	36.864	384	1	36.864	64	6144	6	4	4	1536
96	512	49.152	512	1	49.152	64	6144	8	4	4	1536

**Table 14. Recommended Clock Divider Settings for SCK as Master Clock (continued)**

f <sub>s</sub> (kHz)	RSCK	SCK (MHz)	DSP f <sub>s</sub>	NMAC	DSP CLK (MHz)	MOD f <sub>s</sub>	MOD f (kHz)	NDAC	DOSR	NCP	CP f (kHz)
192	128	24.576	128	1	24.576	32	6144	4	2	4	1536
192	192	36.864	192	1	36.864	32	6144	6	2	4	1536
192	256	49.152	256	1	49.152	32	6144	8	2	4	1536
384	64	24.576	64	1	24.576	16	6144	4	1	4	1536
384	128	49.152	128	1	49.152	16	6144	8	1	4	1536

## Audio Data Interface

### Audio Serial Interface

The audio interface port is a 3-wire serial port with the signals LRCK (pin 15), BCK (pin 13), and DIN (pin 14). BCK is the serial audio bit clock, used to clock the serial data present on DIN into the serial shift register of the audio interface. Serial data is clocked into the PCM514x on the rising edge of BCK. LRCK is the serial audio left/right word clock.

**Table 15. PCM514x Audio Data Formats, Bit Depths and Clock Rates**

CONTROL MODE	FORMAT	DATA BITS	MAX LRCK FREQUENCY [ $f_s$ ]	SCK RATE [ $\times f_s$ ]	BCK RATE [ $\times f_s$ ]
Software Control (SPI or I <sup>2</sup> S)	I <sup>2</sup> S/LJ	32, 24, 20, 16	Up to 192kHz	128 – 3072	64, 48, 32
			384kHz	64, 128	64, 48, 32
	TDM	32, 24, 20, 16	Up to 48kHz	128 – 3072	125, 256
			96kHz	128 – 512	125, 256
Hardware Control	I <sup>2</sup> S/LJ	32, 24, 20, 16	Up to 192kHz	128 – 3072	64, 48, 32
			384kHz	64, 128	64, 48, 32
			192kHz	128, 192, 256	128

The PCM514x requires the synchronization of LRCK and system clock, but does not need a specific phase relation between LRCK and system clock.

If the relationship between LRCK and system clock changes more than  $\pm 5$  SCK, internal operation is initialized within one sample period and analog outputs are forced to the bipolar zero level until resynchronization between LRCK and system clock is completed.

If the relationship between LRCK and BCK are invalid more than 4 LRCK periods, internal operation is initialized within one sample period and analog outputs are forced to the bipolar zero level until resynchronization between LRCK and BCK is completed.

### PCM Audio Data Formats and Timing

The PCM514x supports industry-standard audio data formats, including standard I<sup>2</sup>S and left-justified. Data formats are selected using the FMT (pin 16), Low for I<sup>2</sup>S, and High for Left-justified. All formats require binary 2s-complement, MSB-first audio data; up to 32-bit audio data is accepted.

The PCM514x also supports right-justified and TDM in software control mode. I<sup>2</sup>S, LJ, RJ, and TDM are selected using Register (Pg0Reg40). All formats require binary 2s complement, MSB-first audio data. Up to 32 bits are accepted. Default setting is I<sup>2</sup>S and 24 bit word length. The I<sup>2</sup>S slave timing is shown in [Figure 27](#).

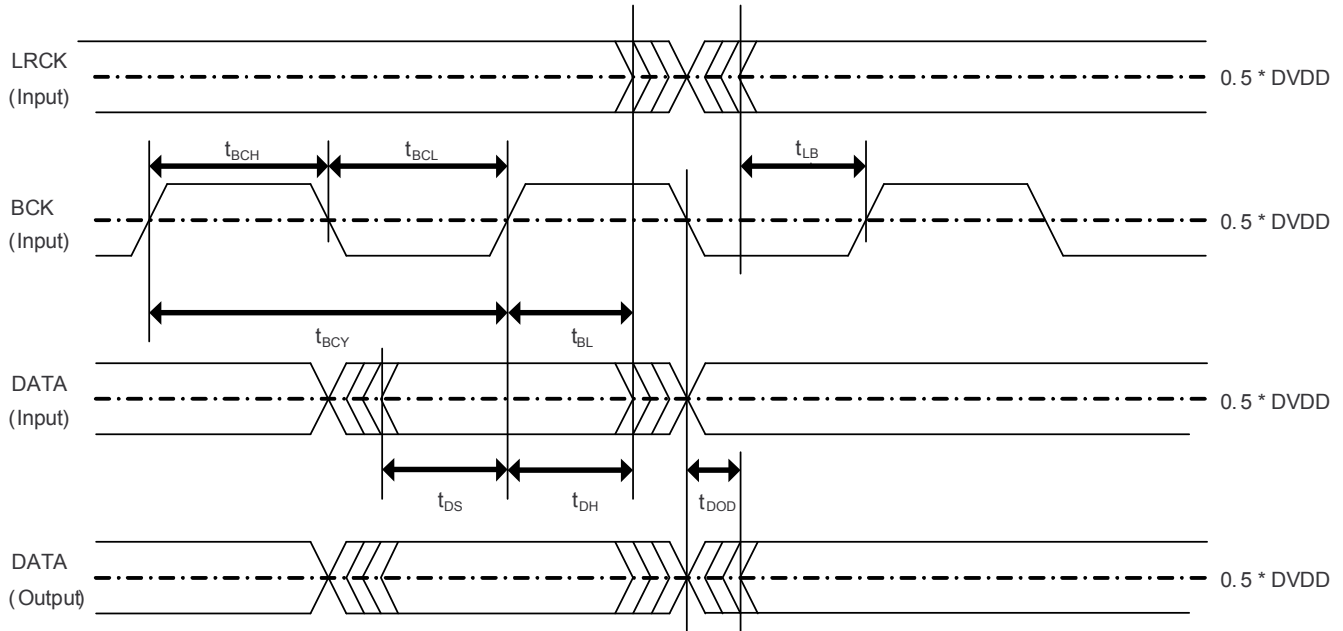

Figure 27. PCM514x Serial Audio Timing - Slave

Table 16. Audio Interface Slave Timing

	Parameters	Min	Max	Units
$t_{BCY}$	BCK Pulse Cycle Time	40		ns
$t_{BCL}$	BCK Pulse Width LOW	16		ns
$t_{BCH}$	BCK Pulse Width HIGH	16		ns
$t_{BL}$	BCK Rising Edge to LRCK Edge	8		ns
$t_{BCK}$	BCK frequency at DVDD = 3.3V		24.576	MHz
$t_{BCK(1.8V)}$	BCK frequency at DVDD = 1.8V		12.288	MHz
$t_{LB}$	LRCK Edge to BCK Rising Edge	8		ns
$t_{DS}$	DATA Set Up Time	8		ns
$t_{DH}$	DATA Hold Time	8		ns
$t_{DOD}$	DATA delay time from BCK falling edge		15	ns

In software mode, the PCM514x can act as an I<sup>2</sup>S master, generating BCK and LRCK as outputs from the SCK input.

Table 17. I<sup>2</sup>S Master Mode Registers

Register	Function
Page0, Register 9, D(0), D(4), and D(5)	I <sup>2</sup> S Master mode select
Register 32, D(6:0)	BCK divider and LRCK divider
Register 33, D(7:0)	

The I<sup>2</sup>S master timing is shown in Figure 28 and Table 18.

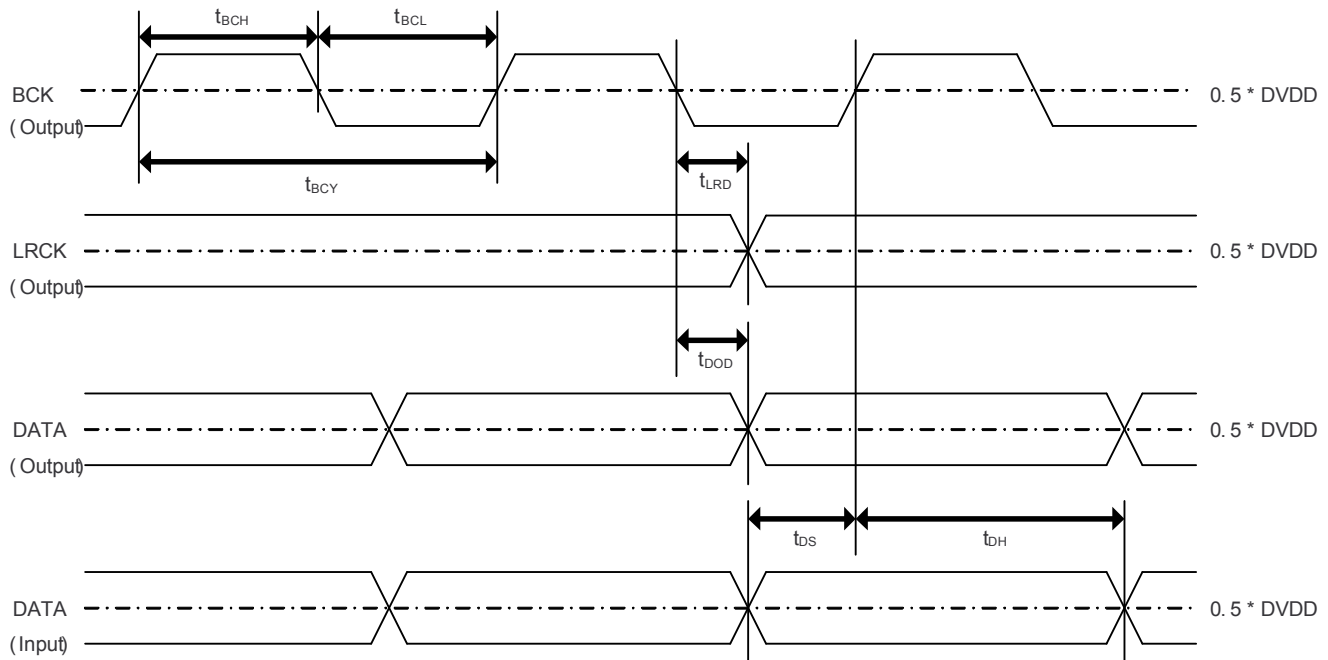

Figure 28. PCM514x Serial Audio Timing - Master

Table 18. Audio Interface Master Timing

	Parameters	Min	Max	Units
$t_{BCY}$	BCK Pulse Cycle Time	40		ns
$t_{BCL}$	BCK Pulse Width LOW	16		ns
$t_{BCH}$	BCK Pulse Width HIGH	16		ns
$t_{BCK}$	BCK frequency at DVDD = 3.3V		24.576	MHz
$t_{BCK(1.8V)}$	BCK frequency at DVDD = 1.8V		12.288	MHz
$t_{LRD}$	LRCKx delay time from BCKx falling edge	-10	20	ns
$t_{DS}$	DATA Set Up Time	8		ns
$t_{DH}$	DATA Hold Time	8		ns
$t_{DOD}$	DATA delay time from BCK falling edge at DVDD = 3.3V		15	ns
$t_{DOD(1.8V)}$	DATA delay time from BCK falling edge at DVDD = 1.8V		20	ns

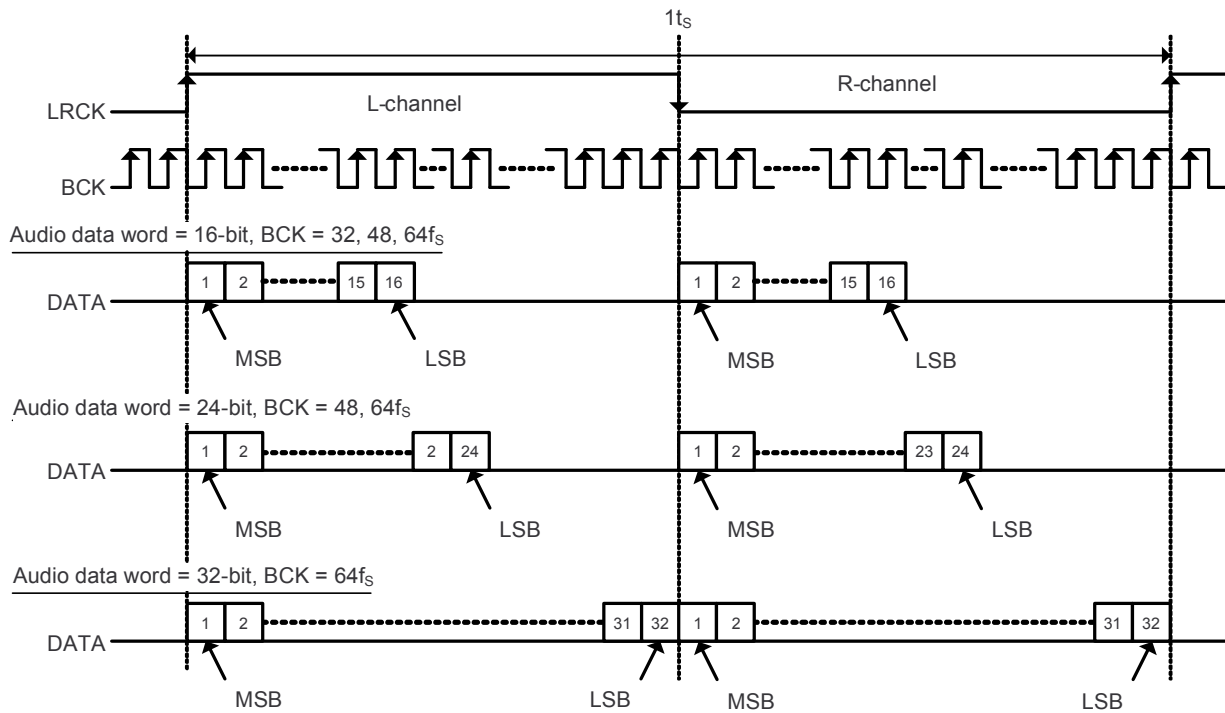

Figure 29. Left Justified Audio Data Format

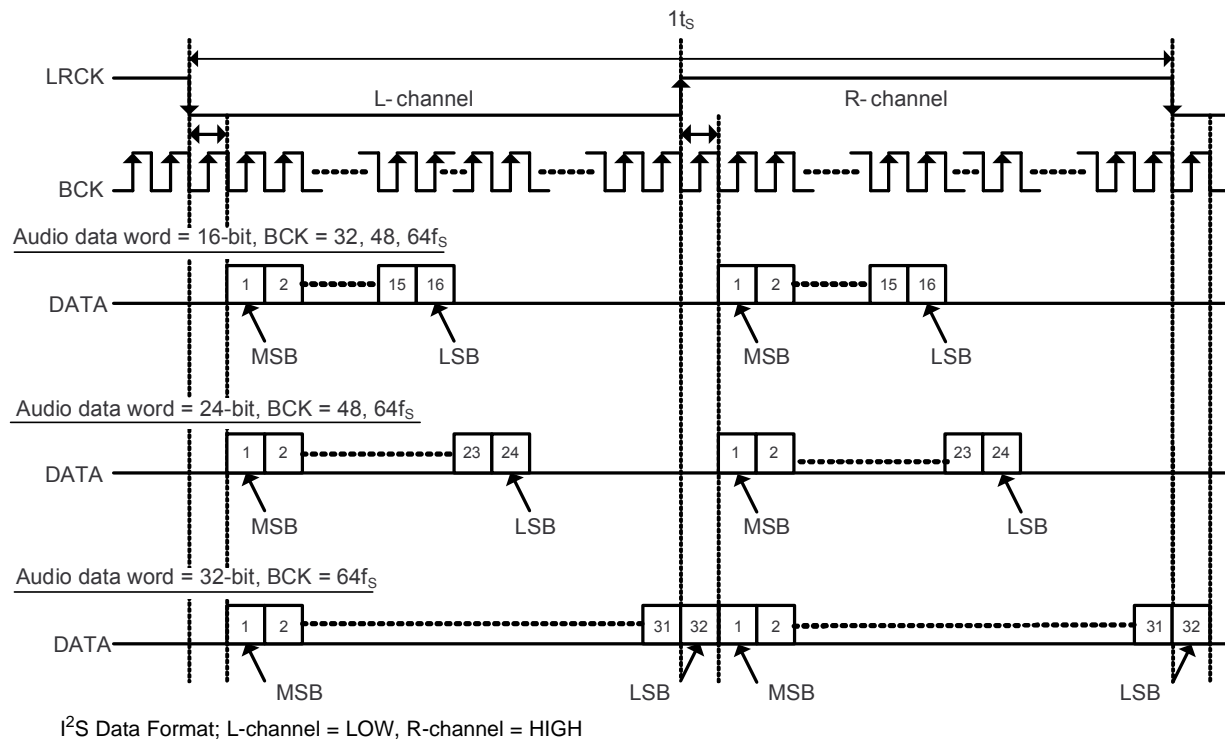

Figure 30. I<sup>2</sup>S Audio Data Format

The following data formats are only available in software mode.

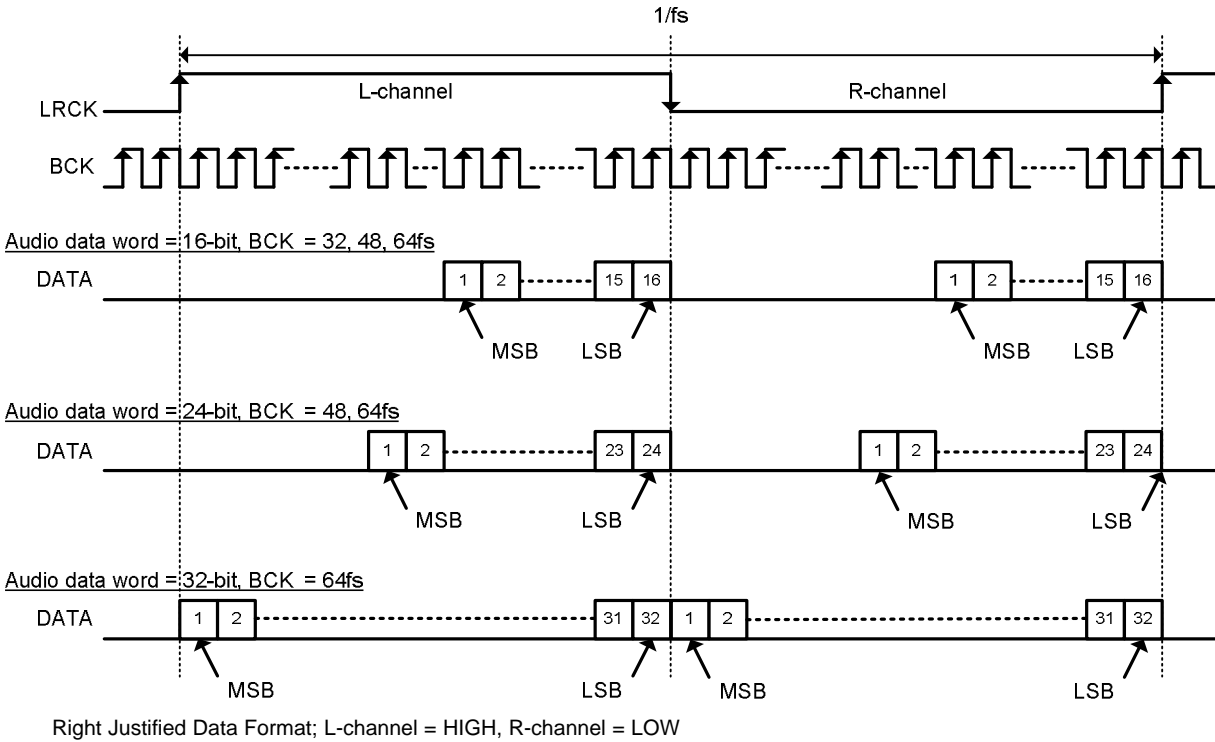

Figure 31. Right Justified Audio Data Format

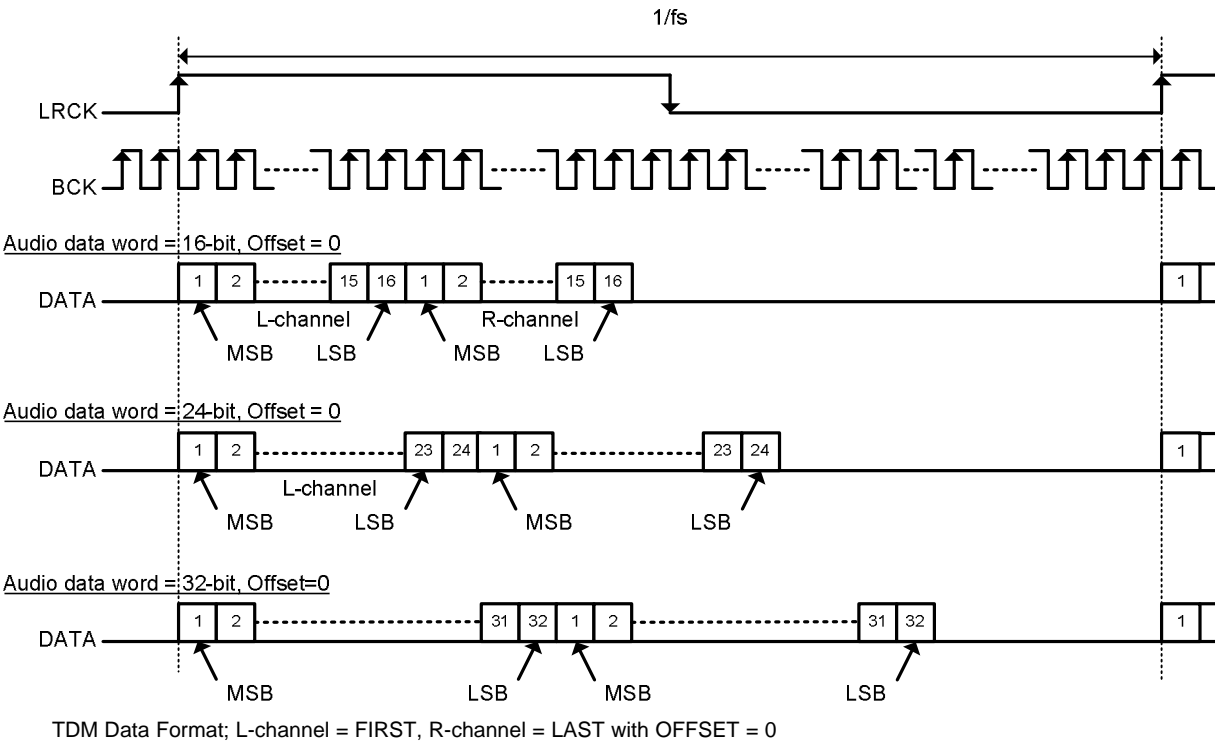

Figure 32. TDM 1 Audio Data Format

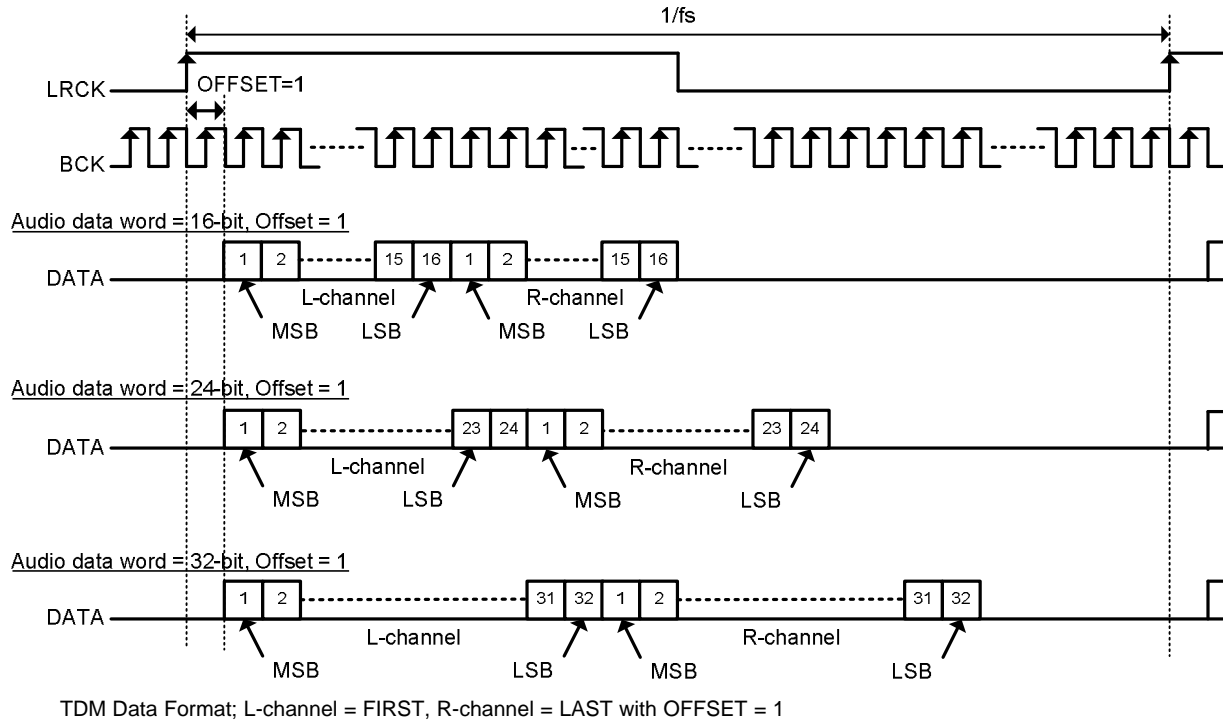

Figure 33. TDM 2 Audio Data Format

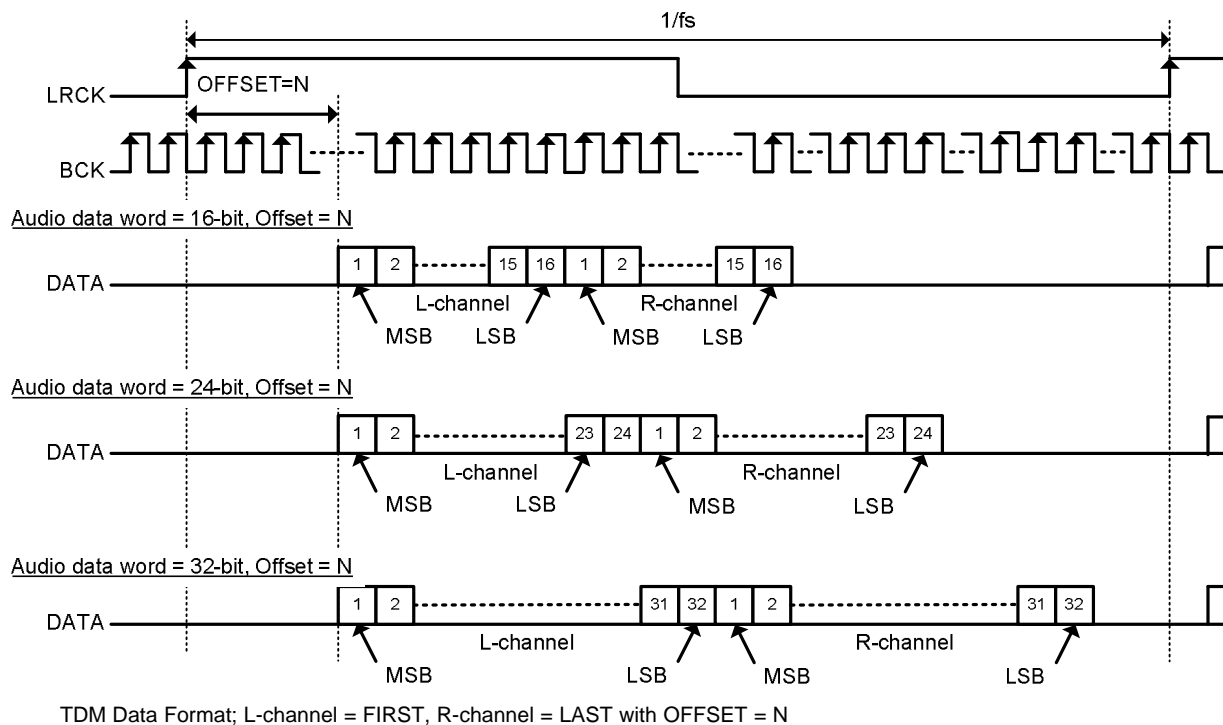

Figure 34. TDM 3 Audio Data Format



## Function Descriptions

### PCM514x Audio Processing Options

#### Overview

The PCM514x features a fully-programmable miniDSP core. The algorithms for the miniDSP must be loaded into the device after power up. The miniDSP has direct access to the digital stereo audio stream, offering the possibility for advanced DSP algorithms with very low group delay. The miniDSP can run up to 1024 instructions on every audio sample at a 48kHz sample rate.

The PCM514x family supports two different code sources. ROM based process flow (Program 5 - [Fixed Audio Processing Flow \(Program 5\)](#) of this datasheet) and RAM based process flow (Program 31). In program 31 (RAM based), different algorithms can be called from ROM - such as EQ, DRC, Zero Crossing volume control etc. Please see the PurePath Studio Development Environment for more details.

#### *miniDSP Instruction Register*

miniDSP instruction registers are only available in PCM514x devices. Page 152-169 registers are 25-bit instructions for the miniDSP engine. For details see [Table 58](#). 7 bits of Instr(32:25) in Base register +0 are reserved bits. 1 bit of Instr(24) - (LSB) in Base register +0 is MSB bit of 25 bit instruction. These instructions control miniDSP operation. When the fully programmable miniDSP mode is enabled and DAC channel is powered up, the read and write access to these registers is disabled.

#### Software

Software development for the PCM514x is supported through TI's comprehensive PurePath Studio Development Environment; a powerful, easy-to-use tool designed specifically to simplify software development on the PCM514x miniDSP audio platform. The Graphical Development Environment consists of a library of common audio functions that can be dragged-and-dropped into an audio signal flow and graphically connected together. The DSP code can then be assembled from the graphical signal flow with the click of a mouse.

Please visit the PCM514x product folder on [www.ti.com](http://www.ti.com) to learn more about PurePath Studio and the latest status on available, ready-to-use DSP algorithms.

## Interpolation Filter

The PCM514x provides 4 types of interpolation filters, selectable by writing to Page 0, Register 43, D(4:0).

**Table 19. ROM Preset Programs**

Program number	D(4:0)	Description	Minimum Cycles
0	0 0000	Reserved	
1	0 0001	Normal x8/x4/x2/x1 Interpolation Filter <sup>(1)</sup>	256
2	0 0010	Low Latency x8/x4/x2/x1 Interpolation Filter <sup>(1)</sup>	256
3	0 0011	High Attenuation x8/x4/x2 Interpolation Filter <sup>(1)</sup>	512
4	0 0100	Reserved	
5	0 0101	Preset Process Flow	n/a
6	0 0110	Reserved	
7	0 0111	Asymmetric FIR Interpolation Filter <sup>(1)</sup>	512
:	:	Reserved	
31	1 1111	RAM program	

(1)  $f_s$  44.1kHz De-emphasis filter is supported.

The PCM514x supports four sampling modes (single rate, dual rate, quad rate, and octal rate) which produce different oversampling rates (OSR) in the interpolation digital filter operation. These are shown in [Table 20](#).

**Table 20. Sampling Modes and Oversampling Rates**

Sampling Mode	Sampling Frequency ( $f_s$ ) kHz	Oversampling Rate (OSR)
Single Rate	8	8 or 16
	16	
	32	
	44.1	
	48	
Dual Rate	88.2	4
	96	
Quad Rate	176.4	2
	192	
Octal Rate	384	1 (Bypass)

**Table 21. Normal x8 Interpolation Filter, Single Rate**

Parameter	Condition	Value (Typical)	Value (Max)	Units
Filter Gain Pass Band	0 ..... 0.45f <sub>S</sub>		±0.01	dB
Filter Gain Stop Band	0.55f <sub>S</sub> ..... 7.455f <sub>S</sub>	-60		dB
Filter Group Delay		20t <sub>S</sub>		S

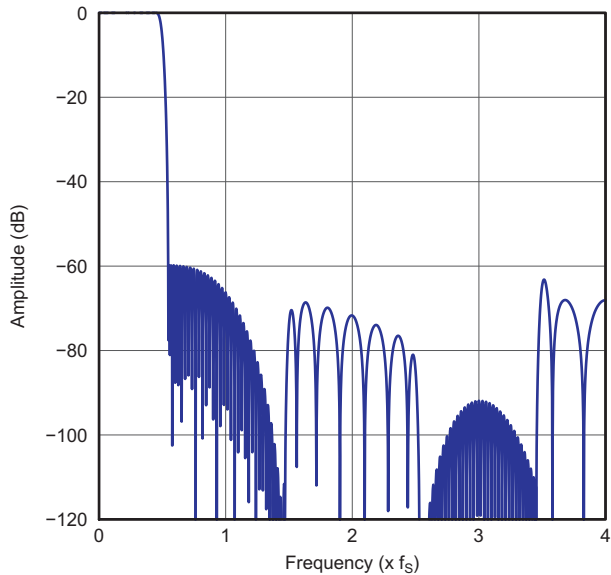

G012

**Figure 35. Normal x8 Interpolation Filter Frequency Response**

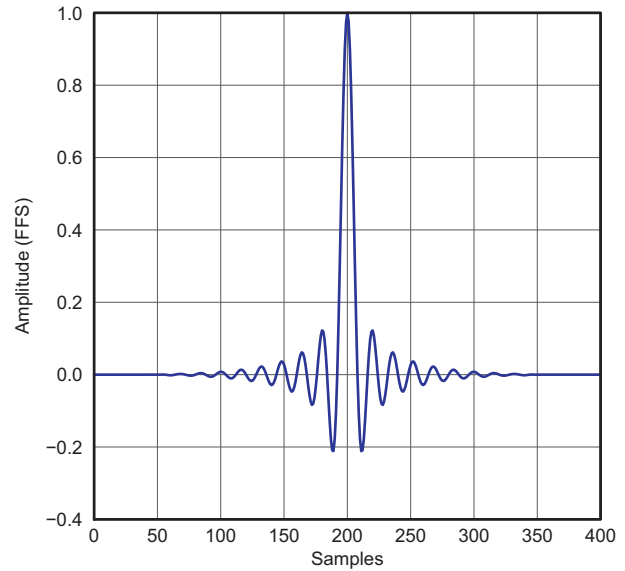

G023

**Figure 36. Normal x8 Interpolation Filter Impulse Response**

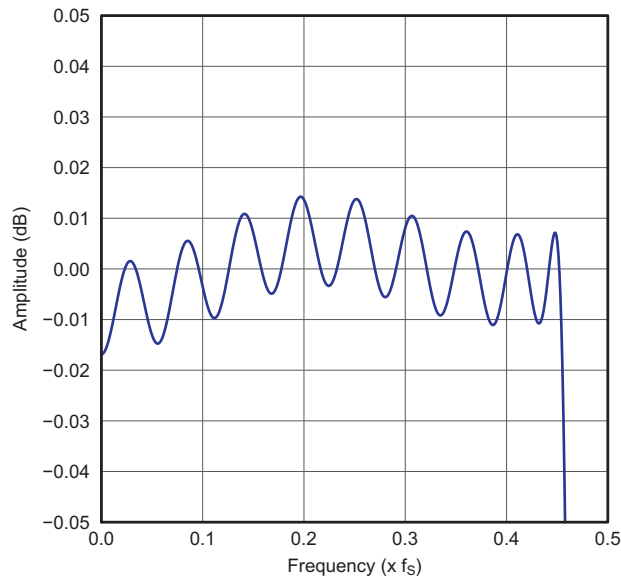

G034

**Figure 37. Normal x8 Interpolation Filter Passband Ripple**

**Table 22. Normal x4 Interpolation Filter, Dual Rate**

Parameter	Condition	Value (Typical)	Value (Max)	Units
Filter Gain Pass Band	0 ..... 0.45f <sub>S</sub>		±0.01	dB
Filter Gain Stop Band	0.55f <sub>S</sub> ..... 3.455f <sub>S</sub>	-60		dB
Filter Group Delay		20t <sub>S</sub>		S

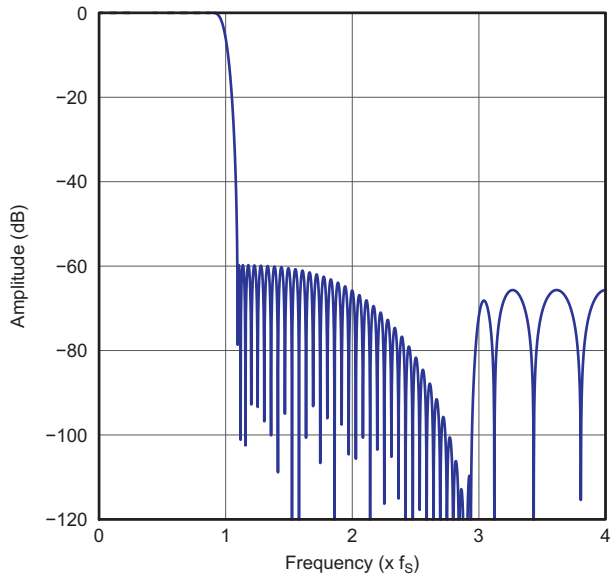

G009

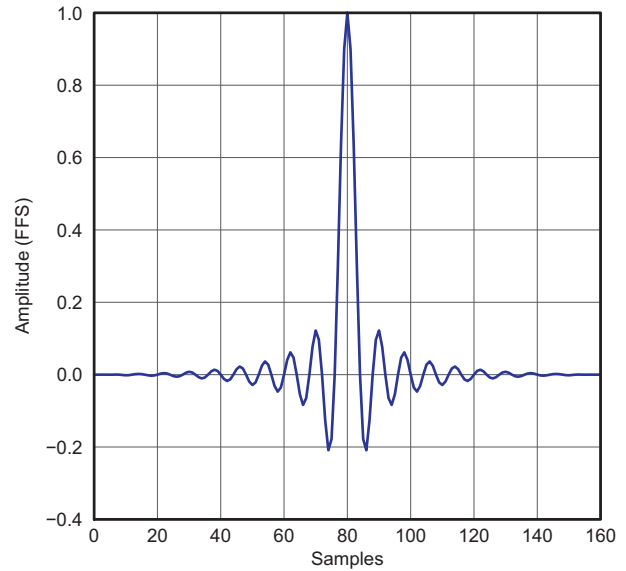

G020

**Figure 38. Normal x4 Interpolation Filter Frequency Response**

**Figure 39. Normal x4 Interpolation Filter Impulse Response**

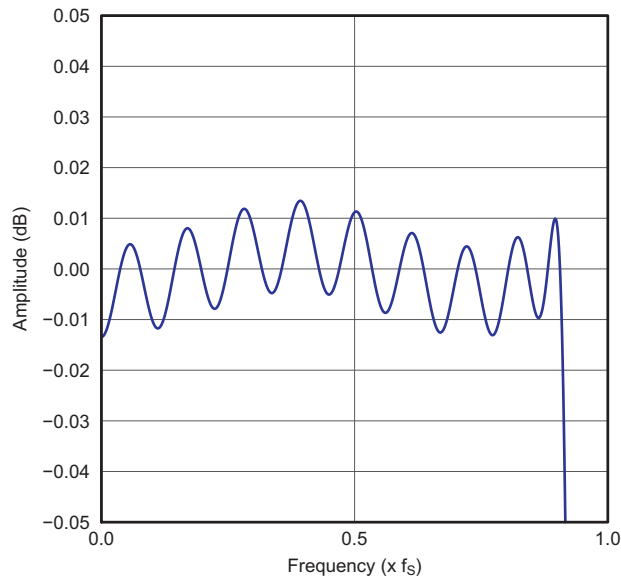

G031

**Figure 40. Normal x4 Interpolation Filter Passband Ripple**

**Table 23. Normal x2 Interpolation Filter, Quad Rate**

Parameter	Condition	Value (Typical)	Value (Max)	Units
Filter Gain Pass Band	0 ..... 0.45f <sub>S</sub>		±0.01	dB
Filter Gain Stop Band	0.55f <sub>S</sub> ..... 1.455f <sub>S</sub>	-60		dB
Filter Group Delay		20t <sub>S</sub>		S

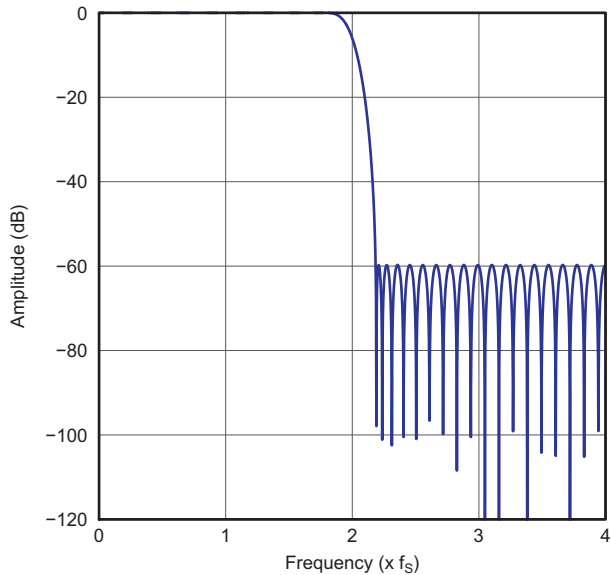

G006

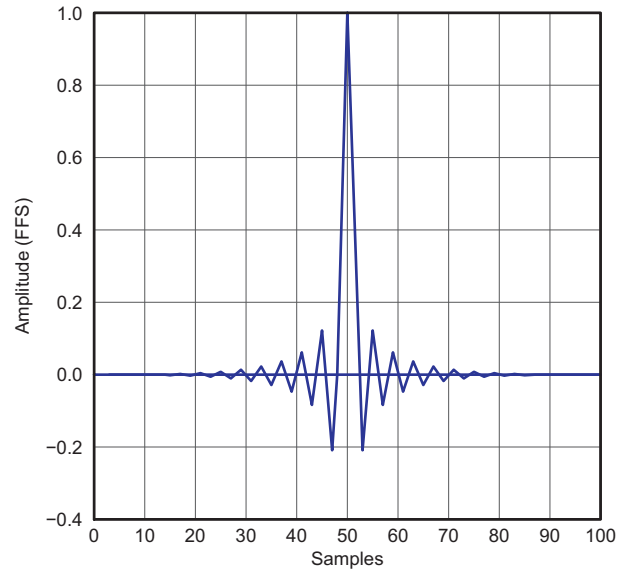

G017

**Figure 41. Normal x2 Interpolation Filter Frequency Response**

**Figure 42. Normal x2 Interpolation Filter Impulse Response**

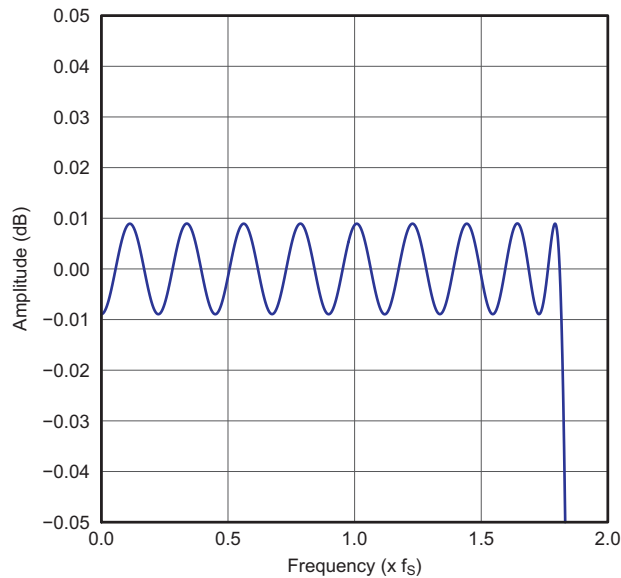

G028

**Figure 43. Normal x2 Interpolation Filter Passband Ripple**

**Table 24. Low latency x8 Interpolation Filter, Single Rate**

Parameter	Condition	Value (Typical)	Value (Max)	Units
Filter Gain Pass Band	0 ..... 0.45f <sub>S</sub>		±0.001	dB
Filter Gain Stop Band	0.55f <sub>S</sub> ..... 7.455f <sub>S</sub>	-52		dB
Filter Group Delay		3.5t <sub>S</sub>		S

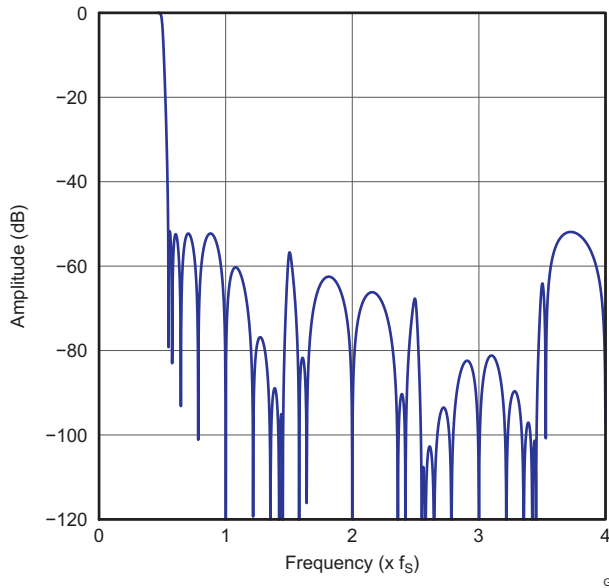

**Figure 44. Low latency x8 Interpolation Filter Frequency Response**

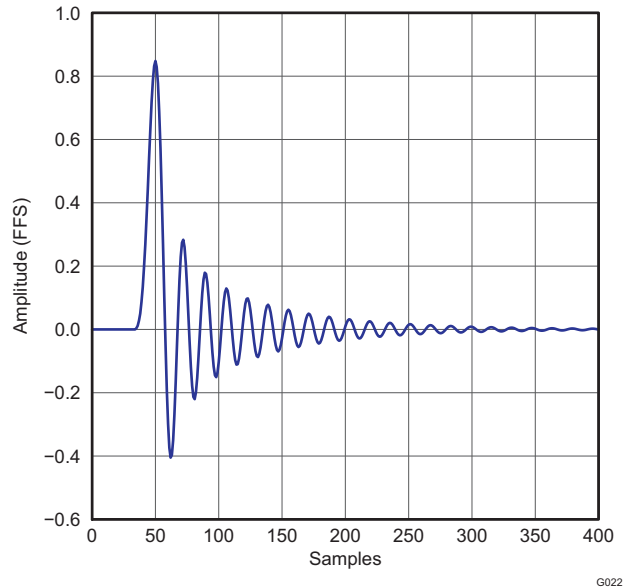

**Figure 45. Low latency x8 Interpolation Filter Impulse Response**

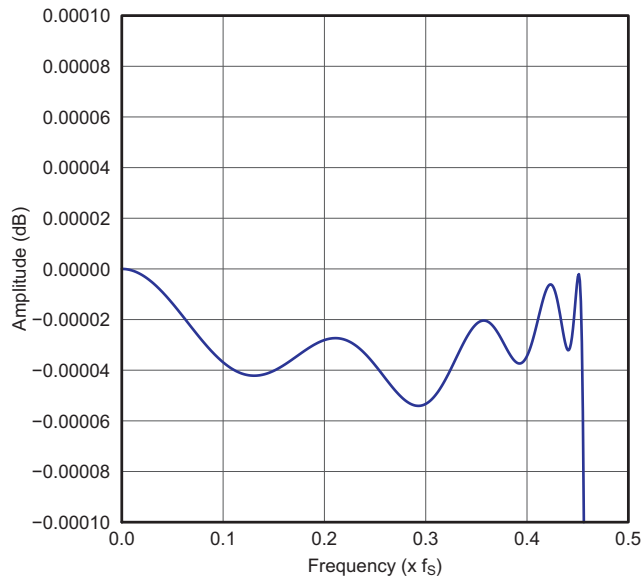

**Figure 46. Low latency x8 Interpolation Filter Passband Ripple**

**Table 25. Low latency x4 Interpolation Filter, Dual Rate**

Parameter	Condition	Value (Typical)	Value (Max)	Units
Filter Gain Pass Band	0 ..... 0.45f <sub>S</sub>		±0.001	dB
Filter Gain Stop Band	0.55f <sub>S</sub> ..... 3.455f <sub>S</sub>	-52		dB
Filter Group Delay		3.5t <sub>S</sub>		S

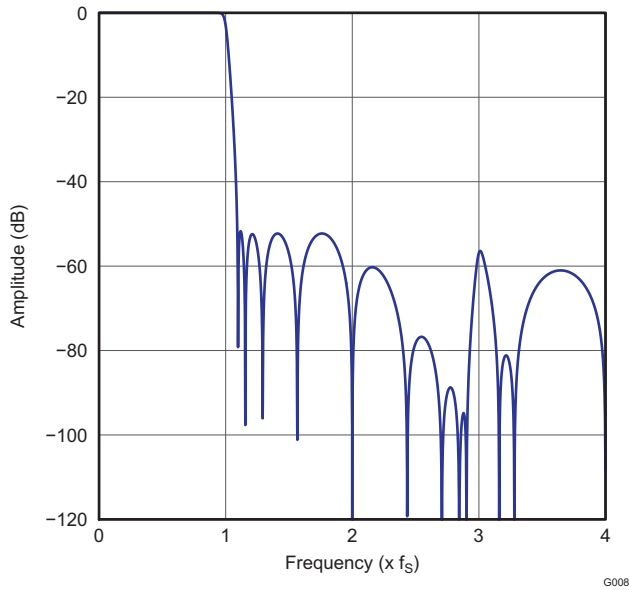

**Figure 47. Low latency x4 Interpolation Filter Frequency Response**

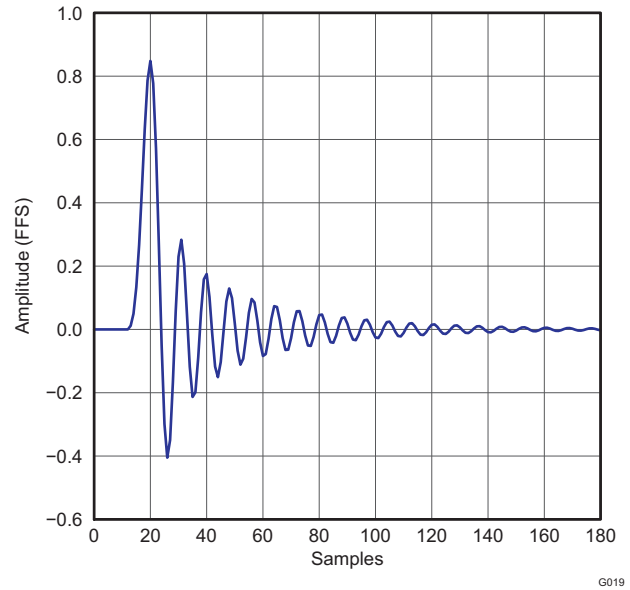

**Figure 48. Low latency x4 Interpolation Filter Impulse Response**

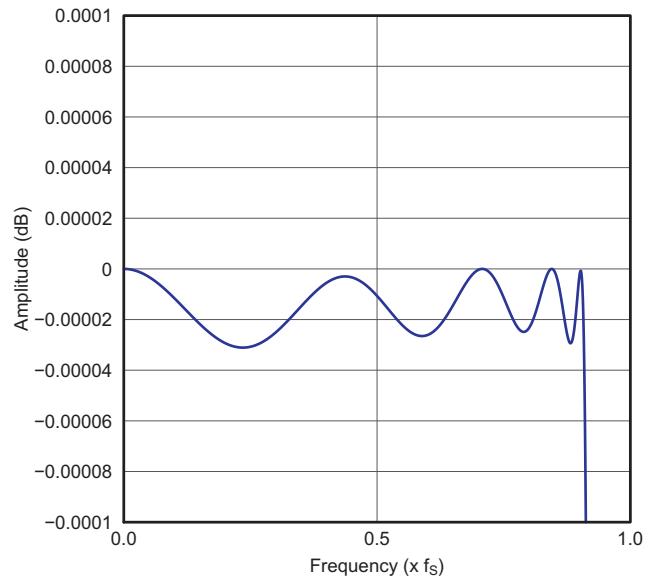

**Figure 49. Low latency x4 Interpolation Filter Passband Ripple**

**Table 26. Low latency x2 Interpolation Filter, Quad Rate**

Parameter	Condition	Value (Typical)	Value (Max)	Units
Filter Gain Pass Band	0 ..... 0.45f <sub>S</sub>		±0.001	dB
Filter Gain Stop Band	0.55f <sub>S</sub> ..... 1.455f <sub>S</sub>	-52		dB
Filter Group Delay		3.5t <sub>S</sub>		S

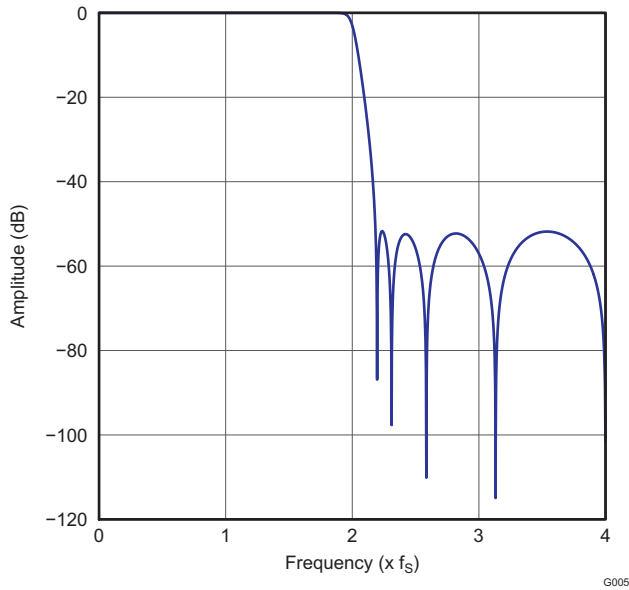

**Figure 50. Low latency x2 Interpolation Filter Frequency Response**

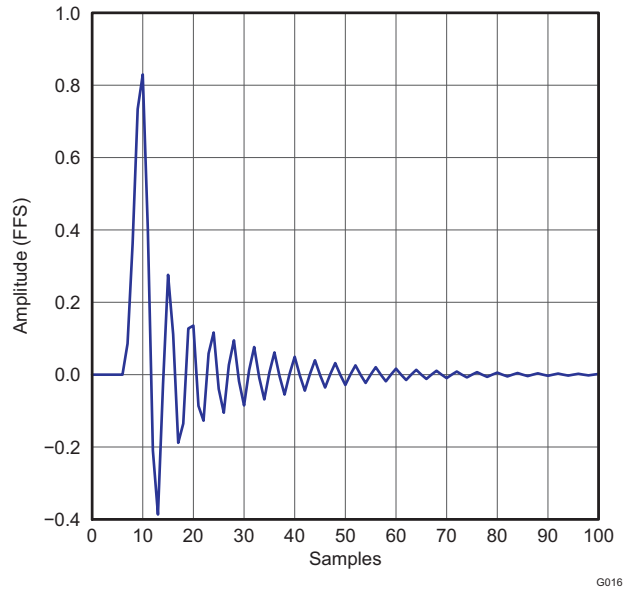

**Figure 51. Low latency x2 Interpolation Filter Impulse Response**

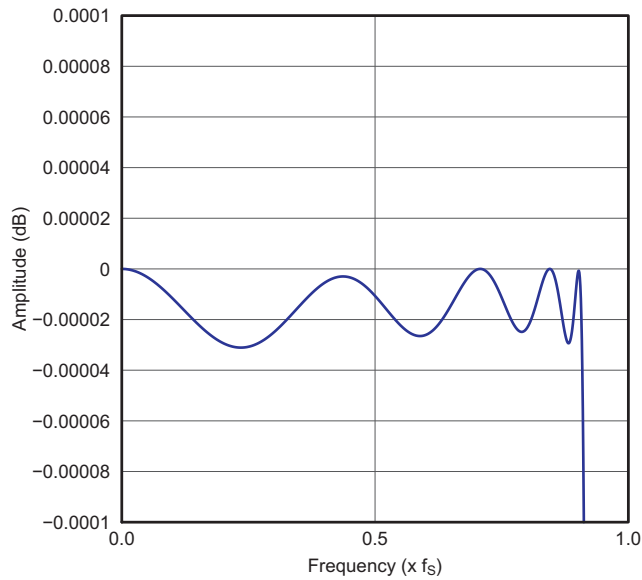
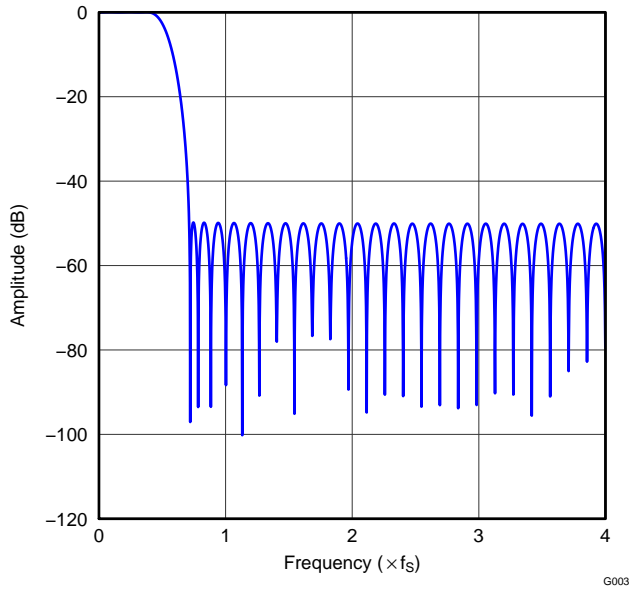

**Figure 52. Low latency x2 Interpolation Filter Passband Ripple**

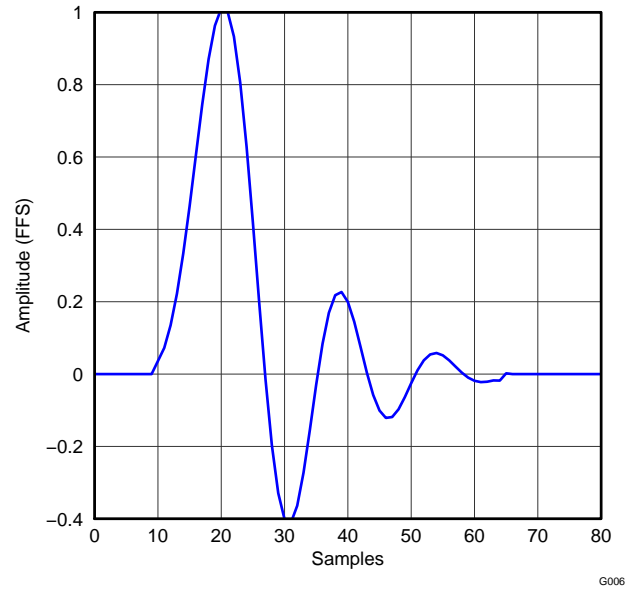

**Table 27. Asymmetric FIR x8 Interpolation Filter, Single Rate**

Parameter	Condition	Value (Typical)	Value (Max)	Units
Filter Gain Pass Band	0 ..... 0.40f <sub>S</sub>		±0.05	dB
Filter Gain Stop Band	0.72f <sub>S</sub> ..... 7.28f <sub>S</sub>	-50		dB
Filter Group Delay		1.2t <sub>S</sub>		S



**Figure 53. Asymmetric FIR x8 Interpolation Filter Frequency Response, Single Rate**



**Figure 54. Asymmetric FIR x8 Interpolation Filter Impulse Response, Single Rate**

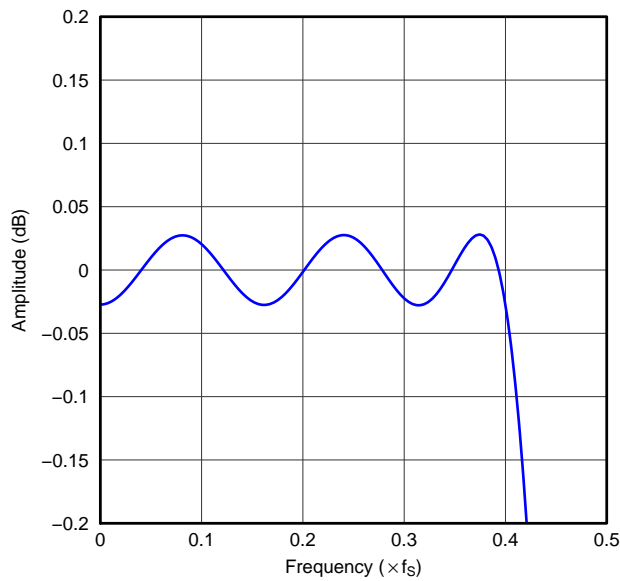

**Figure 55. Asymmetric FIR x8 Interpolation Filter Passband Ripple, Single Rate**

**Table 28. Asymmetric FIR x4 Interpolation Filter, Dual Rate**

Parameter	Condition	Value (Typical)	Value (Max)	Units
Filter Gain Pass Band	0 ..... 0.40f <sub>S</sub>		±0.05	dB
Filter Gain Stop Band	0.72f <sub>S</sub> ..... 3.28f <sub>S</sub>	-50		dB
Filter Group Delay		1.2t <sub>S</sub>		S

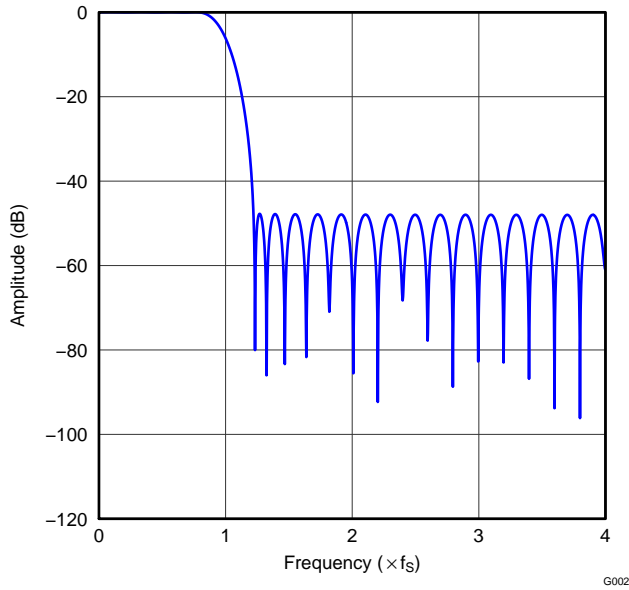

**Figure 56. Asymmetric FIR x4 Interpolation Filter Frequency Response, Dual Rate**

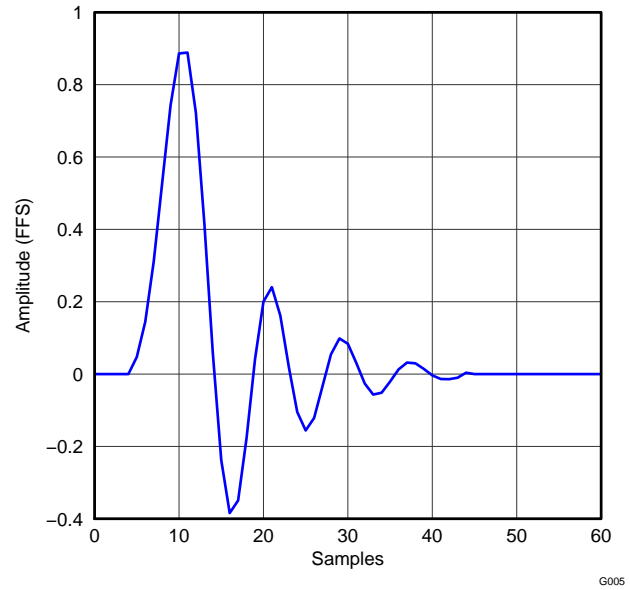

**Figure 57. Asymmetric FIR x4 Interpolation Filter Impulse Response, Dual Rate**

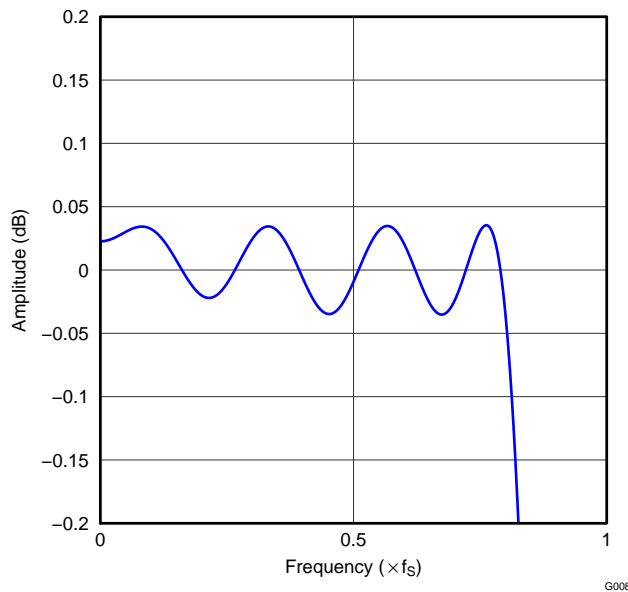

**Figure 58. Asymmetric x4 Interpolation Filter Passband Ripple, Dual Rate**

**Table 29. Asymmetric FIR x2 Interpolation Filter, Quad Rate**

Parameter	Condition	Value (Typical)	Value (Max)	Units
Filter Gain Pass Band	0 ..... 0.40f <sub>S</sub>		±0.05	dB
Filter Gain Stop Band	0.72f <sub>S</sub> ..... 1.28f <sub>S</sub>	-50		dB
Filter Group Delay		1.2t <sub>S</sub>		S

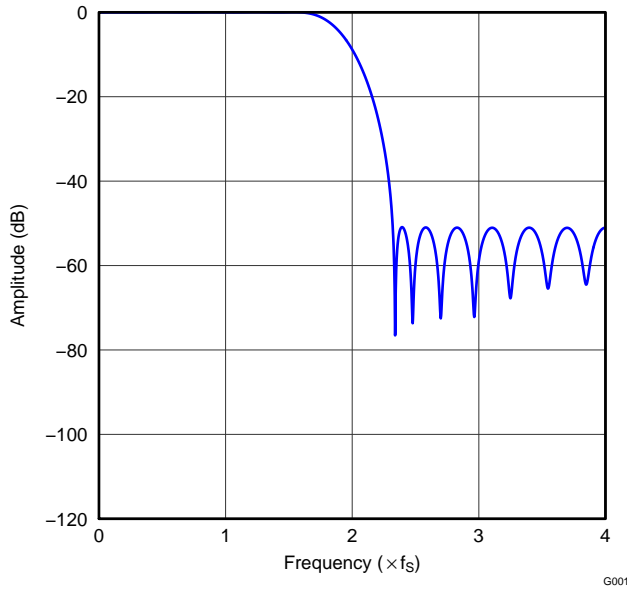

**Figure 59. Asymmetric FIR x2 Interpolation Filter Frequency Response, Quad Rate**

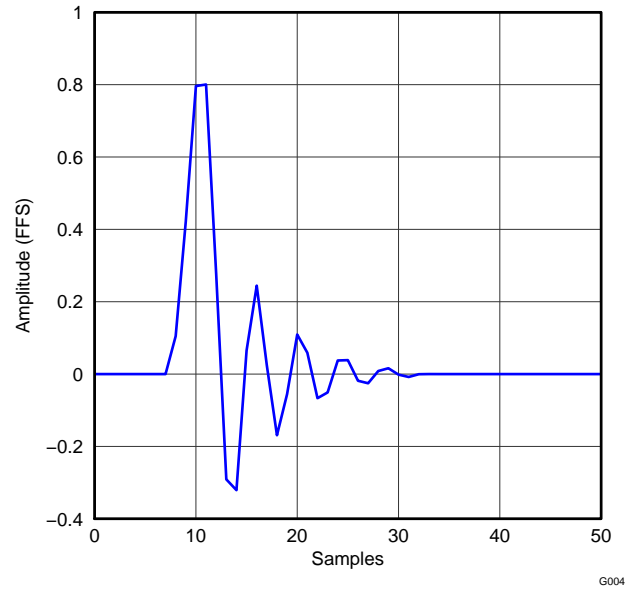

**Figure 60. Asymmetric FIR x2 Interpolation Filter Impulse Response, Quad Rate**

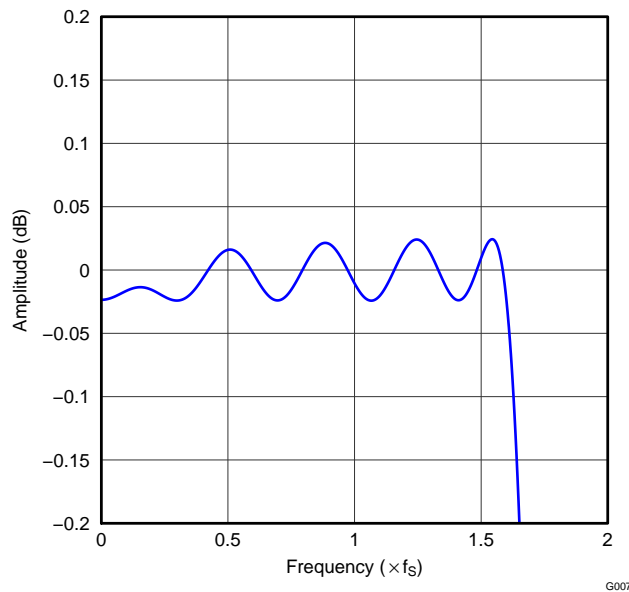

**Figure 61. Asymmetric x2 Interpolation Filter Passband Ripple, Quad Rate**

**Table 30. High-Attenuation x8 Interpolation Filter, Single Rate**

Parameter	Condition	Value (Typical)	Value (Max)	Units
Filter Gain Pass Band	0 ..... 0.45f <sub>s</sub>		±0.0005	dB
Filter Gain Stop Band	0.55f <sub>s</sub> ..... 7.455f <sub>s</sub>	-100		dB
Filter Group Delay		33.7t <sub>s</sub>		S

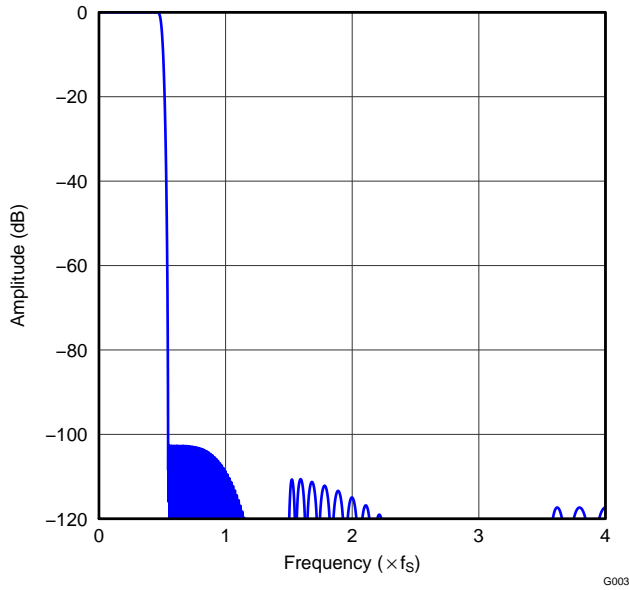

**Figure 62. High-Attenuation x8 Interpolation Filter Frequency Response, Single Rate**

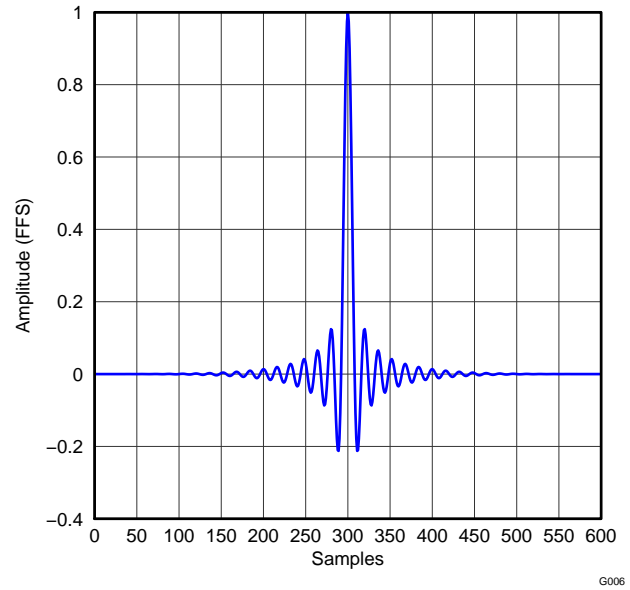

**Figure 63. High-Attenuation x8 Interpolation Filter Impulse Response, Single Rate**

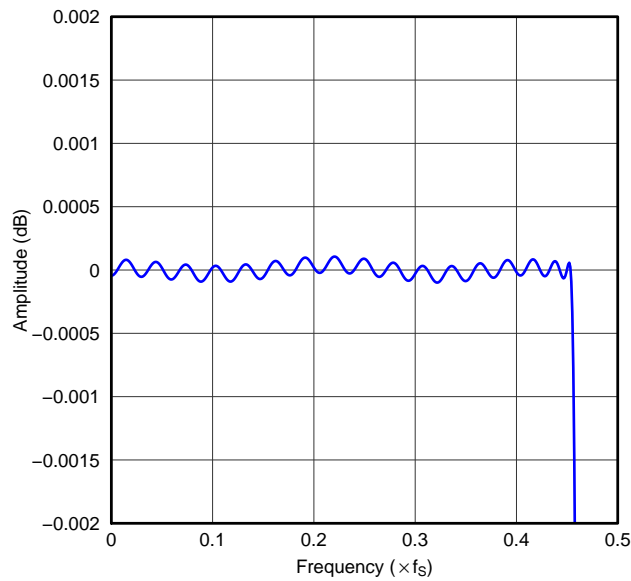

**Figure 64. High-Attenuation x8 Interpolation Filter Passband Ripple, Single Rate**

**Table 31. High-Attenuation x4 Interpolation Filter, Dual Rate**

Parameter	Condition	Value (Typical)	Value (Max)	Units
Filter Gain Pass Band	0 ..... 0.45f <sub>s</sub>		±0.0005	dB
Filter Gain Stop Band	0.55f <sub>s</sub> ..... 3.455f <sub>s</sub>	-100		dB
Filter Group Delay		33.7t <sub>s</sub>		S

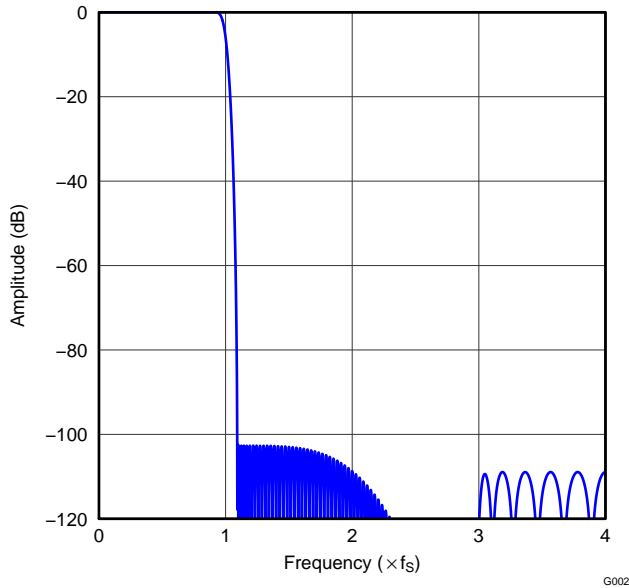

**Figure 65. High-Attenuation x4 Interpolation Filter Frequency Response, Dual Rate**

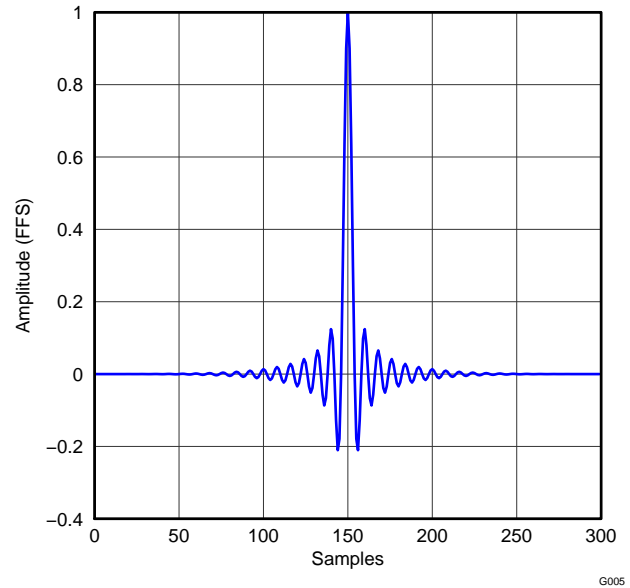

**Figure 66. High-Attenuation x4 Interpolation Filter Impulse Response, Dual Rate**

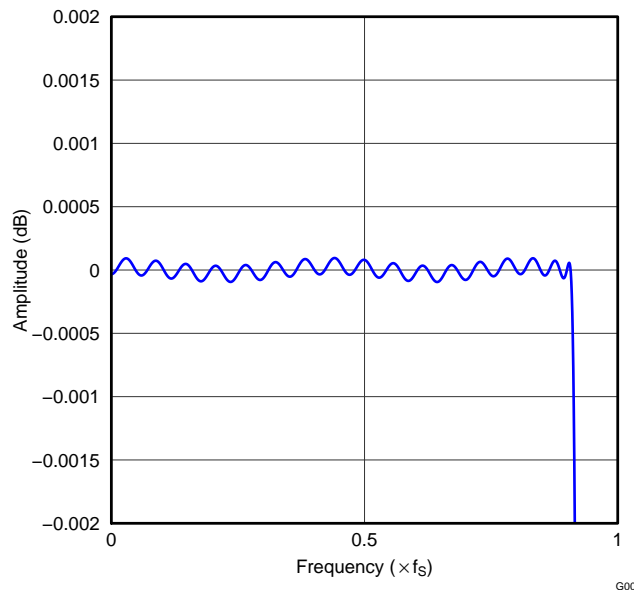

**Figure 67. High-Attenuation x4 Interpolation Filter Passband Ripple, Dual Rate**

**Table 32. High-Attenuation x2 Interpolation Filter, Quad Rate**

Parameter	Condition	Value (Typical)	Value (Max)	Units
Filter Gain Pass Band	0 ..... 0.45f <sub>S</sub>		±0.0005	dB
Filter Gain Stop Band	0.55f <sub>S</sub> ..... 1.455f <sub>S</sub>	-100		dB
Filter Group Delay		33.7t <sub>S</sub>		S

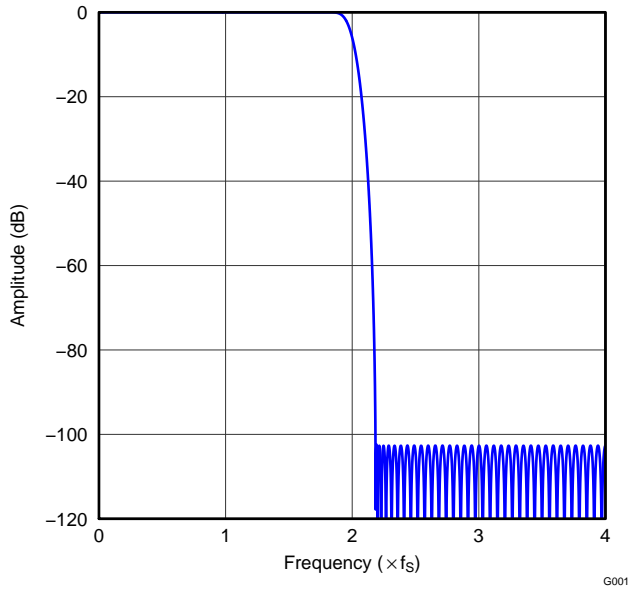

**Figure 68. High-Attenuation x2 Interpolation Filter Frequency Response, Quad Rate**

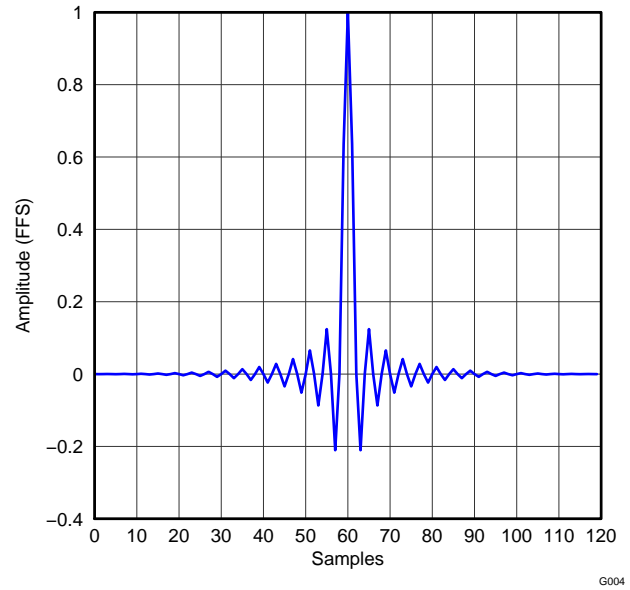

**Figure 69. High-Attenuation x2 Interpolation Filter Impulse Response, Quad Rate**

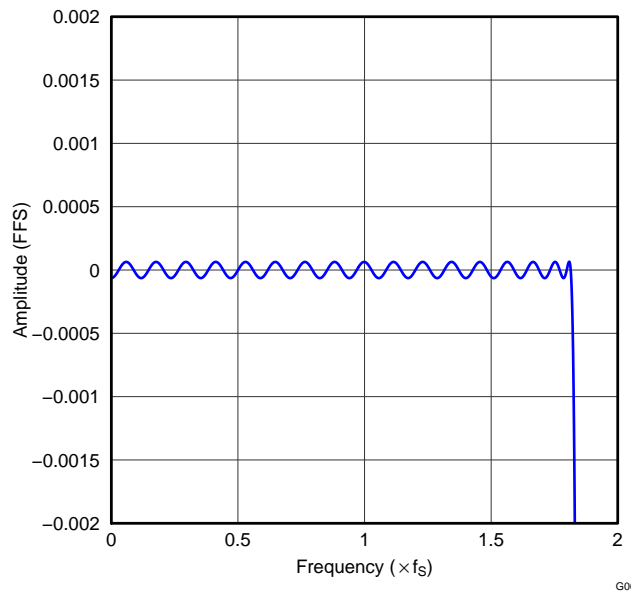

**Figure 70. High-Attenuation x2 Interpolation Filter Passband Ripple, Quad Rate**

## Fixed Audio Processing Flow (Program 5)

The PCM514x family implements signal processing capabilities and interpolation filtering via processing blocks. These fixed processing blocks give users the choice of how much and what type of signal processing they may use and which interpolation filter is applied.

The signal processing blocks available are:

- Biquad filters
- Multiband DRC
- Mono mixer
- Stereo mixer
- Master volume

The addresses of the coefficients are fixed when selecting the fixed processing flow, however, if these components are used in the RAM source mode (Program 31) the registers for coefficients will change. Users can find more details in Purepath Studio.

### Processing Blocks – Detailed Descriptions

Figure 71 shows the fixed processing flow.

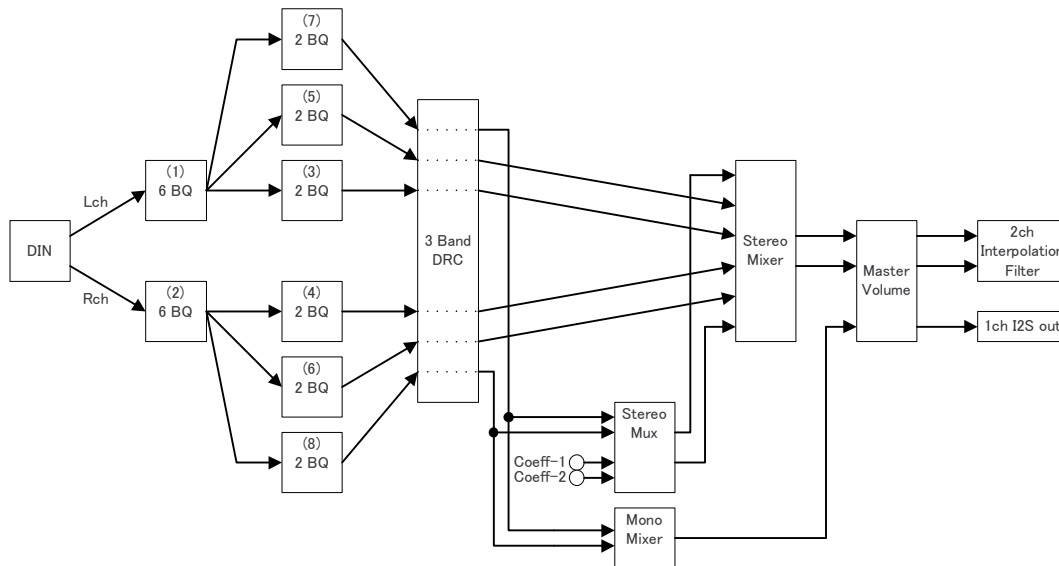

Figure 71. Preset Process Flow

Figure 72 shows a screen capture of PurePath Studio.

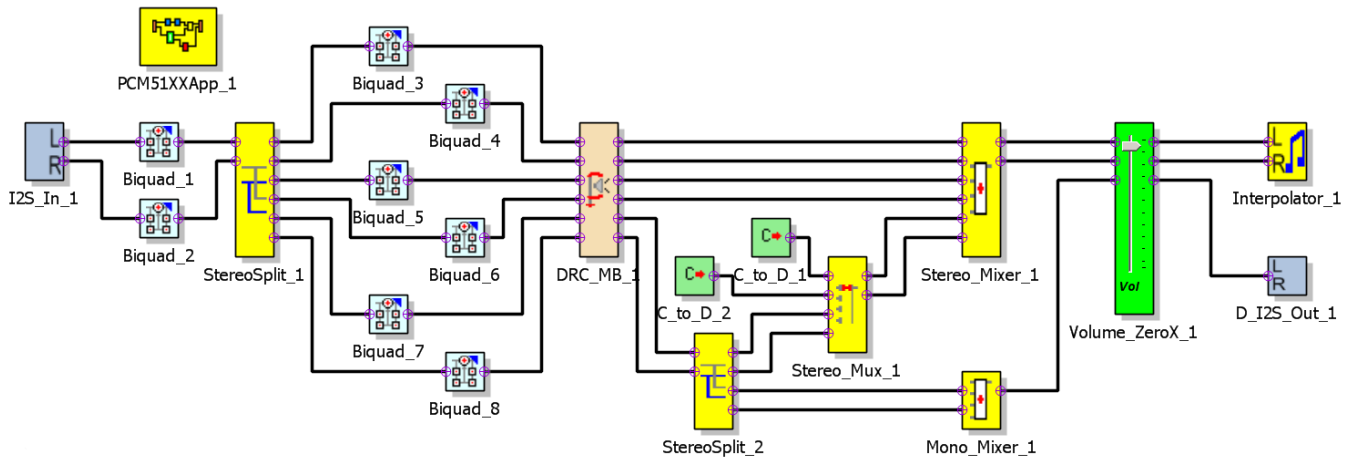

Figure 72. PurePath Studio Screen Capture

**Biquad Section**

The transfer function of each of the biquad filters is given by

$$H(z) = \frac{N_0 + 2N_1z^{-1} + N_2z^{-2}}{2^{23} - 2D_1z^{-1} - D_2z^{-2}} \tag{2}$$

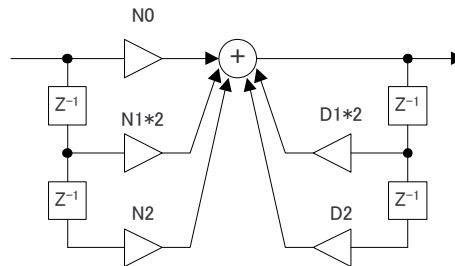

Figure 73. Biquad Block

Table 33. Biquad Filter Coefficients

Filter	Channel	Coefficient	Register
BIQUAD (1) - 1 BIQUAD (2) - 1	Lch, Rch	N0	C10 (Pg 44, Reg 48,49,50,51)
		N1	C11 (Pg 44, Reg 52,53,54,55)
		N2	C12 (Pg 44, Reg 56,57,58,59)
		D1	C13 (Pg 44, Reg 60,61,62,63)
		D2	C14 (Pg 44, Reg 64,65,66,67)
BIQUAD (1) - 2 BIQUAD (2) - 2	Lch, Rch	N0	C15 (Pg 44, Reg 68,69,70,71)
		N1	C16 (Pg 44, Reg 72,73,74,75)
		N2	C17 (Pg 44, Reg 76,77,78,79)
		D1	C18 (Pg 44, Reg 80,81,82,83)
		D2	C19 (Pg 44, Reg 84,85,86,87)



**Table 33. Biquad Filter Coefficients (continued)**

Filter	Channel	Coefficient	Register
BIQUAD (1) - 3 BIQUAD (2) - 3	Lch, Rch	N0	C20 (Pg 44, Reg 88,89,90,91)
		N1	C21 (Pg 44, Reg 92,93,94,95)
		N2	C22 (Pg 44, Reg 96,97,98,99)
		D1	C23 (Pg 44, Reg 100,101, 102, 103)
		D2	C24 (Pg 44, Reg 104, 105, 106, 107)
BIQUAD (1) - 4 BIQUAD (2) - 4	Lch, Rch	N0	C25 (Pg 44, Reg 108, 109, 110, 111)
		N1	C26 (Pg 44, Reg 112, 113, 114, 115)
		N2	C27 (Pg 44, Reg 116, 117, 118, 119)
		D1	C28 (Pg 44, Reg 120, 121, 122, 123)
		D2	C29 (Pg 44, Reg 124, 125, 126, 127)
BIQUAD (1) - 5 BIQUAD (2) - 5	Lch, Rch	N0	C30 (Pg 45, Reg 8, 9, 10, 11)
		N1	C31 (Pg 45, Reg 12, 13, 14, 15)
		N2	C32 (Pg 45, Reg 16, 17, 18, 19)
		D1	C33 (Pg 45, Reg 20, 21, 22, 23)
		D2	C34 (Pg 45, Reg 24, 25, 26, 27)
BIQUAD (1) - 6 BIQUAD (2) - 6	Lch, Rch	N0	C35 (Pg 45, Reg 28, 29, 30, 31)
		N1	C36 (Pg 45, Reg 32, 33, 34, 35)
		N2	C37 (Pg 45, Reg 36, 37, 38, 39)
		D1	C38 (Pg 45, Reg 40, 41, 42, 43)
		D2	C39 (Pg 45, Reg 44, 45, 46, 47)
BIQUAD (3) - 1 BIQUAD (4) - 1	Lch, Rch	N0	C40 (Pg 45, Reg 48, 49, 50, 51)
		N1	C41 (Pg 45, Reg 52, 53, 54, 55)
		N2	C42 (Pg 45, Reg 56, 57, 58, 59)
		D1	C43 (Pg 45, Reg 60, 61, 62, 63)
		D2	C44 (Pg 45, Reg 64, 65, 66, 67)
BIQUAD (3) - 2 BIQUAD (4) - 2	Lch, Rch	N0	C45 (Pg 45, Reg 68, 69, 70, 71)
		N1	C46 (Pg 45, Reg 72, 73, 74, 75)
		N2	C47 (Pg 45, Reg 76, 77, 78, 79)
		D1	C48 (Pg 45, Reg 80, 81, 82, 83)
		D2	C49 (Pg 45, Reg 84, 85, 86, 87)
BIQUAD (5) - 1 BIQUAD (6) - 1	Lch, Rch	N0	C50 (Pg 45, Reg 88, 89, 90, 91)
		N1	C51 (Pg 45, Reg 92, 93, 94, 95)
		N2	C52 (Pg 45, Reg 96, 97, 98, 99)
		D1	C53 (Pg 45, Reg 100, 101, 102, 103)
		D2	C54 (Pg 45, Reg 104, 105, 106, 107)
BIQUAD (5) - 2 BIQUAD (6) - 2	Lch, Rch	N0	C55 (Pg 45, Reg 108, 109, 110, 111)
		N1	C56 (Pg 45, Reg 112, 113, 114, 115)
		N2	C57 (Pg 45, Reg 116, 117, 118, 119)
		D1	C58 (Pg 45, Reg 120, 121, 122, 123)
		D2	C59 (Pg 45, Reg 124, 125, 126, 127)
BIQUAD (7) - 1 BIQUAD (8) - 1	Lch, Rch	N0	C60 (Pg 46, Reg 8, 9, 10, 11)
		N1	C61 (Pg 46, Reg 12, 13, 14, 15)
		N2	C62 (Pg 46, Reg 16, 17, 18, 19)
		D1	C63 (Pg 46, Reg 20, 21, 22, 23)
		D2	C64 (Pg 46, Reg 24, 25, 26, 27)

**Table 33. Biquad Filter Coefficients (continued)**

Filter	Channel	Coefficient	Register
BIQUAD (7) - 2 BIQUAD (8) - 2	Lch, Rch	N0	C65 (Pg 46, Reg 28, 29, 30, 31)
		N1	C66 (Pg 46, Reg 32, 33, 34, 35)
		N2	C67 (Pg 46, Reg 36, 37, 38, 39)
		D1	C68 (Pg 46, Reg 40, 41, 42, 43)
		D2	C69 (Pg 46, Reg 44, 45, 46, 47)

### Dynamic Range Compression

Dynamic range compression (DRC) improves the overall listening experience. Typical music signals are characterized by crest factors (the ratio of peak signal power to average signal power) of 12dB or more. To avoid audible distortion due to clipping of peak signals, the gain of the DAC channel must be adjusted so as not to cause hard clipping. As a result, the low applied gain during nominal periods causes the perception that the signal is not loud enough. To overcome this problem, the DRC in the PCM514x continuously monitors the output of the DAC Digital Volume control to detect its power level with respect to 0dB full-scale. When the power level is low, the DRC increases the input signal gain to make it sound louder, and reduces the gain during peaks to avoid hard clipping. The DRC enables louder audio during nominal periods with a clearer, more pleasant listening experience.

The 3-band DRC function applies DRC to 3 different mono/stereo signals with 3 different time constants. The same DRC curve is applied on all the signals, enabling a multi-band DRC solution. The underlying DRC algorithm is the same as that available with the DRC component in PurePath Studio. In this instance, the DRC gain acts on each signal in time-multiplexed order, for example, 1-2-3, 1-2-3, 1-2-3.

**Table 34. DRC Coefficients**

Coefficient	Register	Description
DRC_MB_1_DRC_1_DRCAE	C70 (Pg 46, Reg 48, 49, 50, 51)	
DRC_MB_1_DRC_1_DRC1AE	C71 (Pg 46, Reg 52, 53, 54, 55)	
DRC_MB_1_DRC_1_DRCAA	C72 (Pg 46, Reg 56, 57, 58, 59)	
DRC_MB_1_DRC_1_DRC1AA	C73 (Pg 46, Reg 60, 61, 62, 63)	
DRC_MB_1_DRC_1_DRCAD	C74 (Pg 46, Reg 64, 65, 66, 67)	
DRC_MB_1_DRC_1_DRC1AD	C75 (Pg 46, Reg 68, 69, 70, 71)	
DRC_MB_1_DRC_2_DRCAE	C76 (Pg 46, Reg 72, 73, 74, 75)	
DRC_MB_1_DRC_2_DRC1AE	C77 (Pg 46, Reg 76, 77, 78, 79)	
DRC_MB_1_DRC_2_DRCAA	C78 (Pg 46, Reg 80, 81, 82, 83)	
DRC_MB_1_DRC_2_DRC1AA	C79 (Pg 46, Reg 84, 85, 86, 87)	
DRC_MB_1_DRC_2_DRCAD	C80 (Pg 46, Reg 88, 89, 90, 91)	
DRC_MB_1_DRC_2_DRC1AD	C81 (Pg 46, Reg 92, 93, 94, 95)	
DRC_MB_1_DRC_3_DRCAE	C82 (Pg 46, Reg 96, 97, 98, 99)	
DRC_MB_1_DRC_3_DRC1AE	C83 (Pg 46, Reg 100, 101, 102, 103)	
DRC_MB_1_DRC_3_DRCAA	C84 (Pg 46, Reg 104, 105, 106, 107)	
DRC_MB_1_DRC_3_DRC1AA	C85 (Pg 46, Reg 108, 109, 110, 111)	
DRC_MB_1_DRC_3_DRCAD	C86 (Pg 46, Reg 112, 113, 114, 115)	
DRC_MB_1_DRC_3_DRC1AD	C87 (Pg 46, Reg 116, 117, 118, 119)	
DRC_MB_1_DRC_DRCK0	C88 (Pg 46, Reg 120, 121, 122, 123)	
DRC_MB_1_DRC_DRCK1	C89 (Pg 46, Reg 124, 125, 126, 127)	
DRC_MB_1_DRC_DRCK2	C90 (Pg 47, Reg 8, 9, 10, 11)	
DRC_MB_1_DRC_DRCMT1	C91 (Pg 47, Reg 12, 13, 14, 15)	
DRC_MB_1_DRC_DRCMT2	C92 (Pg 47, Reg 16, 17, 18, 19)	
DRC_MB_1_DRC_DRCOFF1	C93 (Pg 47, Reg 20, 21, 22, 23)	
DRC_MB_1_DRC_DRCOFF2	C94 (Pg 47, Reg 24, 25, 26, 27)	
DRC_MB_1_MinusOne_Q22	C95 (Pg 47, Reg 28, 29, 30, 31)	

**Table 34. DRC Coefficients (continued)**

<b>Coefficient</b>	<b>Register</b>	<b>Description</b>
DRC_MB_1_MinusTwo_Q22	C96 (Pg 47, Reg 32, 33, 34, 35)	
DRC_MB_1_One_M2	C97 (Pg 47, Reg 36, 37, 38, 39)	
DRC_MB_1_Zero	C98 (Pg 47, Reg 40, 41, 42, 43)	
DRC_MB_1_En_dB	C99 (Pg 47, Reg 44, 45, 46, 47)	
DRC_MB_1_Minus_Zero_dB	C100 (Pg 47, Reg 48, 49, 50, 51)	
DRC_MB_1_60_dB	C101 (Pg 47, Reg 52, 53, 54, 55)	
DRC_MB_1_Minus_60_dB	C102 (Pg 47, Reg 56, 57, 58, 59)	
DRC_MB_1_12_dB	C103 (Pg 47, Reg 60, 61, 62, 63)	
DRC_MB_1_Offset	C104 (Pg 47, Reg 64, 65, 66, 67)	
DRC_MB_1_K	C105 (Pg 47, Reg 68, 69, 70, 71)	
DRC_MB_1_x / DRC_MB_1_DRC	C106 (Pg 47, Reg 72, 73, 74, 75)	
DRC_MB_1_48_dB	C107 (Pg 47, Reg 76, 77, 78, 79)	
DRC_MB_1_Minus_48_dB	C108 (Pg 47, Reg 80, 81, 82, 83)	
DRC_MB_1_c1_3	C109 (Pg 47, Reg 84, 85, 86, 87)	
DRC_MB_1_c1_2	C110 (Pg 47, Reg 88, 89, 90, 91)	
DRC_MB_1_c1_1	C111 (Pg 47, Reg 92, 93, 94, 95)	
DRC_MB_1_c1_0	C112 (Pg 47, Reg 96, 97, 98, 99)	
DRC_MB_1_O1_1	C113 (Pg 47, Reg 100, 101, 102, 103)	
DRC_MB_1_S1_1	C114 (Pg 47, Reg 104, 105, 106, 107)	
DRC_MB_1_O1_2	C115 (Pg 47, Reg 108, 109, 119, 111)	
DRC_MB_1_S1_2	C116 (Pg 47, Reg 112, 113, 114, 115)	
DRC_MB_1_O1_3	C117 (Pg 47, Reg 116, 117, 118, 119)	
DRC_MB_1_S1_3	C118 (Pg 47, Reg 120, 121, 122, 123)	
DRC_MB_1_One_1_Q17	C119 (Pg 47, Reg 124, 125, 126, 127)	
DRC_MB_1_Scale1	C120 (Pg 48, Reg 8, 9, 10, 11)	
DRC_MB_1_x1Coeff	C121 (Pg 48, Reg 12, 13, 14, 15)	
DRC_MB_1_c2_3	C122 (Pg 48, Reg 16, 17, 18, 19)	
DRC_MB_1_c2_2	C123 (Pg 48, Reg 20, 21, 22, 23)	
DRC_MB_1_c2_1	C124 (Pg 48, Reg 24, 25, 26, 27)	
DRC_MB_1_c2_0	C125 (Pg 48, Reg 28, 29, 30, 31)	
DRC_MB_1_O2_1	C126 (Pg 48, Reg 32, 33, 34, 35)	
DRC_MB_1_S2_1	C127 (Pg 48, Reg 36, 37, 38, 39)	
DRC_MB_1_O2_2	C128 (Pg 48, Reg 40, 41, 42, 43)	
DRC_MB_1_S2_2	C129 (Pg 48, Reg 44, 45, 46, 47)	
DRC_MB_1_O2_3	C130 (Pg 48, Reg 48, 49, 50, 51)	
DRC_MB_1_S2_3	C131 (Pg 48, Reg 52, 53, 54, 55)	
DRC_MB_1_One_2_Q17	C132 (Pg 48, Reg 56, 57, 58, 59)	
DRC_MB_1_Scale2	C133 (Pg 48, Reg 60, 61, 62, 63)	
DRC_MB_1_x2Coeff	C134 (Pg 48, Reg 64, 65, 66, 67)	
DRC_MB_1_R1_1	C135 (Pg 48, Reg 68, 69, 70, 71)	
DRC_MB_1_R1_2	C136 (Pg 48, Reg 72, 73, 74, 75)	
DRC_MB_1_R2_1	C137 (Pg 48, Reg 76, 77, 78, 79)	
DRC_MB_1_R2_2	C138 (Pg 48, Reg 80, 81, 82, 83)	
DRC_MB_1_Band1_GainC	C139 (Pg 48, Reg 84, 85, 86, 87)	
DRC_MB_1_Band2_GainC	C140 (Pg 48, Reg 88, 89, 90, 91)	
DRC_MB_1_Band3_GainC	C141 (Pg 48, Reg 92, 93, 94, 95)	
DRC_MB_1_MinusOne_M1	C142 (Pg 48, Reg 96, 97, 98, 99)	

**Table 34. DRC Coefficients (continued)**

Coefficient	Register	Description
DRC_MB_1_One_M1	C143 (Pg 48, Reg 100, 101, 102, 103)	
DRC_MB_1_Band1_GainE	C144 (Pg 48, Reg 104, 105, 106, 107)	
DRC_MB_1_Band2_GainE	C145 (Pg 48, Reg 108, 109, 110, 111)	
DRC_MB_1_Band3_GainE	C146 (Pg 48, Reg 112, 113, 114, 115)	
DRC_MB_1_minus_One_M2	C147 (Pg 48, Reg 116, 117, 118, 119)	

**Stereo Mixer**

Three stereo inputs are mixed into one stereo output with input signal gain given by [Equation 3](#).

$$Out\_L(n) = \sum (Input\_L(i,n) \cdot Gain(i))$$

where

- $i=1:2,3$  (3)

[Figure 74](#) and [Table 35](#) show the stereo mixer operation.

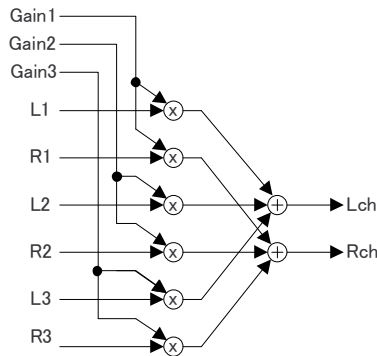

**Figure 74. Figure 4. Stereo Mixer Block**

**Table 35. Stereo Mixer Coefficients**

Coefficient	Register	Description
Stereo_Mixer_1_MixGain1	C148 (Pg 48, Reg 120, 121, 122, 123)	
Stereo_Mixer_1_MixGain2	C149 (Pg 48, Reg 124, 125, 126, 127)	
Stereo_Mixer_1_MixGain3	C150 (Pg 49, Reg 8, 9, 10, 11)	

**Stereo Multiplexer**

The Stereo Multiplexer selects one or 2 from 4 stereo input channels.

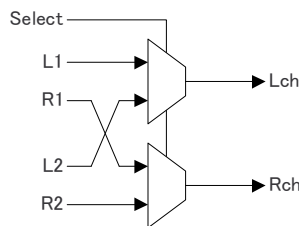

**Figure 75. Stereo Multiplexer Block**

**Table 36. Stereo Multiplexer Select Coefficient**

Coefficient	Register	Description
Stereo_Mux_1_MuxSelect	C152 (Pg 49, Reg 16, 17, 18, 19)	

**Table 37. Stereo Multiplexer Input Coefficient**

Coefficient	Register	Description
C_to_D_1_Coefval C_to_D_2_Coefval	C153 (Pg 49, Reg 20, 21, 22, 23)	

**Mono Mixer**

The Mono Mixer computes a weighted sum of 2 input channels and produces an output.

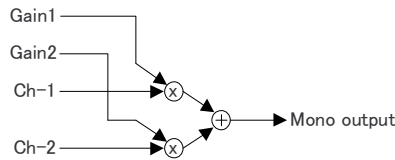

**Figure 76. Figure 6. Mono Mixer Block**

**Table 38. Mono Mixer Coefficients**

Coefficient	Register	Description
Mono_Mixer_1_MixGain1	C154 (Pg 49, Reg 24, 25, 26, 27)	
Mono_Mixer_1_MixGain2	C155 (Pg 49, Reg 28, 29, 30, 31)	

**Master Volume Control**

The Master Volume controls the volume using a linear ramp and zero crossing detection for transitions.

**Table 39. Mono Mixer Coefficients**

Coefficient	Register	Description
Volume_ZeroX_1_volcmd	C158 (Pg 49, Reg 40, 41, 42, 43)	
Volume_ZeroX_1_volout	C159 (Pg 49, Reg 44, 45, 46, 47)	
Volume_ZeroX_1_volout_loudness	C160 (Pg 49, Reg 48, 49, 50, 51)	
Volume_ZeroX_1_MinusOne_M2	C161 (Pg 49, Reg 52, 53, 54, 55)	
Volume_ZeroX_1_workingval_1_pre_CRAM	C162 (Pg 49, Reg 56, 57, 58, 59)	
Volume_ZeroX_1_volout_pre1	C163 (Pg 49, Reg 60, 61, 62, 63)	
Volume_ZeroX_1_workingval_2_pre_CRAM	C164 (Pg 49, Reg 64, 65, 66, 67)	
Volume_ZeroX_1_volout_pre2	C165 (Pg 49, Reg 68, 69, 70, 71)	
Volume_ZeroX_1_workingval_3_pre_CRAM	C166 (Pg 49, Reg 72, 73, 74, 75)	
Volume_ZeroX_1_volout_pre3	C167 (Pg 49, Reg 76, 77, 78, 79)	
Volume_ZeroX_1_One_M2	C168 (Pg 49, Reg 80, 81, 82, 83)	
Volume_ZeroX_1_Zero	C169 (Pg 49, Reg 84, 85, 86, 87)	
MinusOne_Int	C170 (Pg 49, Reg 88, 89, 90, 91)	
MinusOne_M1	C171 (Pg 49, Reg 92, 93, 94, 95)	
One_M2	C172 (Pg 49, Reg 96, 97, 98, 99)	
One_M1	C173 (Pg 49, Reg 100, 101, 102, 103)	
Zero	C174 (Pg 49, Reg 104, 105, 106, 107)	

## Miscellaneous Coefficients

**Table 40. Miscellaneous Coefficients**

Coefficient	Register	Description
DRC_MB_1_DataBlock	C175 (Pg 49, Reg 108, 109, 110, 111)	
DRC_MB_1_CoeffBlock	C176 (Pg 49, Reg 112, 113, 114, 115)	
Volume_ZeroX_1_DataBlock	C177 (Pg 49, Reg 116, 117, 118, 119)	
Volume_ZeroX_1_CoeffBlock	C178 (Pg 49, Reg 120, 121, 122, 123)	
plus_one	C179 (Pg 49, Reg 124, 125, 126, 127)	
ADD_OF_filter_in_L	C180 (Pg 50, Reg 8, 9, 10, 11)	
ADD_OF_filter_in_R	C181 (Pg 50, Reg 12, 13, 14, 15)	

## Analog Gain Control

Analog gain control can be selected between  $2V_{rms}$  FS (0dB) or  $1V_{rms}$  FS (-6dB). Gain is controlled via hardware by the AGNS pin, and via software (SPI/I<sup>2</sup>C), Page 1, Register 2, D4(L-ch) / D0(R-ch).

## Digital Volume Control

A basic digital volume control with range from 24 dB to -103 dB and mute is available on each channels by Page 0, Register 61, D(7:0) for L-ch and Register 62, D(7:0) for R-ch. These volume controls all have 0.5 dB step programmability over most gain and attenuation ranges. [Table 41](#) lists the detailed gain versus programmed setting for this basic volume control. Volume can be changed for both L-ch and R-ch at the same time or independently by Page 0, Register 60, D(1:0). When D(1:0) set 00 (default), independent control is selected. When D(1:0) set 01, R-ch accords with L-ch volume. When D(1:0) set 10, L-ch accords with R-ch volume. To set D(1:0) to 11 is prohibited.

**Table 41. Digital Volume Control Settings**

Gain Setting	Binary Data	Gain (dB)	Comments
0	0000-0000	24.0	Positive maximum
1	0000-0001	23.5	
:	:	:	
46	0010-1110	1.0	
47	0010-1111	0.5	
48	0011-0000	0.0	No attenuation (default)
49	0011-0001	- 0.5	
50	0011-0010	- 1.0	
51	0011-0011	- 1.5	
:	:	:	
253	1111-1101	- 102.5	
254	1111-1110	- 103	Negative maximum
255	1111-1111	- ∞	Negative infinite (Mute)

Ramp-up frequency and ramp-down frequency can be controlled by Page 0, Register 63, D(7:6) and D(3:2) as shown in [Table 42](#). Also Ramp-up step and ramp-down step can be controlled by Page 0, Register 63 D(5:4) and D(1:0) as shown in [Table 43](#).

**Table 42. Ramp Up or Down Frequency**

Ramp up speed	Every N f <sub>s</sub>	Comments	Ramp down frequency	Every N f <sub>s</sub>	Comments
00	1	Default	00	1	Default
01	2		01	2	
10	4		10	4	

**Table 42. Ramp Up or Down Frequency (continued)**

11	Direct change		11	Direct change	
----	---------------	--	----	---------------	--

**Table 43. Ramp Up or Down Step**

Ramp up step	Step dB	Comments	Ramp down step	Step dB	Comments
00	4.0		00	-4.0	
01	2.0		01	-2.0	
10	1.0	Default	10	-1.0	Default
11	0.5		11	-0.5	

### Emergency Ramp Down

Digital volume emergency ramp down by is provided for situations such as I<sup>2</sup>S clock error and power supply failure. Ramp-down speed is controlled by Page 0, Register 64, D(7:6). Ramp-down step can be controlled by Page 0 Register 64, D(5:4). Default is ramp-down by every  $f_s$  cycle with -4dB step.

### Zero Data Detect

The PCM514x has a zero-detect function. When the device detects the continuous zero data for both L-ch and R-cn, or separate L-cn and R-ch, Analog mutes are set to both OUTL and OUTR, or separate OUTL and OUTR. These are controlled by Page0, Register 65, D(2:1) as shown in [Table 44](#).

Continuous Zero data cycles are counted by LRCK, and the threshold of decision for analog mute can be set by Page 0, Register 59, D(6:4) for L-ch, and D(2:0) for Rch as shown in [Table 45](#). Default values are 0 for both channels.

In Hardware mode, the device uses default values.

**Table 44. Zero Detection Mode**

ATMUTECTL	Value	Function
Bit : 2	0	Independently L-ch or R-ch are zero data for zero detection
	1 (Default)	Both L-ch and R-ch have to be zero data for zero detection
Bit : 1	0	Zero detection and analog mute are disabled for R-ch
	1 (Default)	Zero detection analog mute are enabled for R-ch
Bit : 0	0	Zero detection analog mute are disabled for L-ch
	1 (Default)	Zero detection analog mute are enabled for L-ch

**Table 45. Zero Data Detection Time**

ATMUTETIML / ATMUTETIMR	Number of LRCKs	Time @ 48kHz
0 0 0	1024	21 ms
0 0 1	5120	106 ms
0 1 0	10240	213 ms
0 1 1	25600	533 ms
1 0 0	51200	1.066 sec
1 0 1	102400	2.133 sec
1 1 0	256000	5.333 sec
1 1 1	512000	10.66 sec

## Power Save Modes

The PCM514x offers two power-save modes; standby and power-down.

When a clock error (SCK, BCK, and LRCK) or clock halt is detected, the PCM514x automatically enters standby mode. The DAC and line driver are also powered down. The device can also be placed in standby mode via software command.

When BCK and LRCK remain at a low level for more than 1 second, the PCM514x automatically enters power-down mode. Power-down mode disables the negative charge pump and bias/reference circuit, in addition to those disabled in standby mode. The device can also be placed in power-down mode via software command.

The detection time of BCK and LRCK halt can be controlled by Page 0, Register 44, D(2:0).

When expected Audio clocks (SCK, BCK, LRCK) are applied to the PCM514x, the device starts its powerup sequence automatically. The detection time for BCK and LRCK halt is programmable.



## Power Save Parameter Programming

Register	Description
Page 0, Register 2, D(4)	Software standby mode command
Page 0, Register 2, D(0)	Software power-down command
Page 0, Register 2, D(4) and D(0)	Software power-up sequence command (required after software standby or power-down)
Page 0, Register 44, D(2:0)	Detection time of BCK and LRCK halt

### XSMT Pin (Soft Mute / Soft Un-Mute)

For external digital control of the PCM514x, the XSMT pin needs to be driven by an external digital host with a specific/minimum rising time ( $t_r$ ) and falling time ( $t_f$ ) for soft mute and soft un-mute. The PCM514x expects  $t_r/t_f$  times of less than 20ns. In the majority of applications, this shouldn't be a problem, however, traces with high capacitance may have issues.

When the XSMT pin is shifted from high to low (3.3V to 0V), a soft digital attenuation ramp is started. -1dB attenuation will be applied every sample time from 0dBFS to  $-\infty$ . The soft attenuation ramp takes 104 sample times.

When the XSMT pin is shifted from low to high (0V to 3.3V), a soft digital "un-mute" is started. 1dB gain steps are applied every sample time from  $-\infty$  to 0dBFS. The un-mute takes 104 sample times.

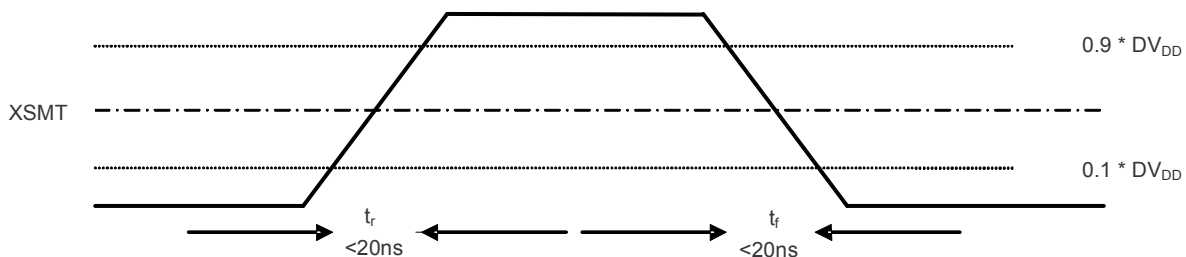

Figure 77. XSMT Timing for Soft Mute and Soft Un-Mute

Table 46. XSMT Timing Parameters

Parameters	Min	Max	Unit
Rise time ( $t_r$ )		20	ns
Fall time ( $t_f$ )		20	ns

### External Power Sense Undervoltage Protection mode (supported only when DVDD = 3.3V)

The XSMT pin can also be used to monitor a system voltage, such as the 24VDC LCD TV backlight, or 12VDC system supply using a voltage divider created with two resistors. (See [Figure 78](#) )

- If the XSMT pin makes a transition from “1” to “0” over 6ms or more, the device switches into external undervoltage protection mode. This mode uses two trigger levels.
- When the XSMT pin level reaches 2V, soft mute process begins.
- When the XSMT pin level reaches 1.2V, analog mute engages, regardless of digital audio level, and analog shutdown begins. (DAC and related circuitry powers down).

A timing diagram to show this is shown in [Figure 79](#).

#### NOTE

The XSMT input pin voltage range is from  $-0.3V$  to  $DVDD + 0.3V$ . The ratio of external resistors must produce a voltage within this input range. Any increase in power supply (such as power supply positive noise or ripple) can pull the XSMT pin higher than  $DVDD+0.3V$ .

For example, if the PCM514x is monitoring a 12V input, and dividing the voltage by 4, then the voltage at XSMT during ideal power supply conditions will be 3V. A voltage spike higher than 14.4V causes a voltage greater than 3.6V ( $DVDD+0.3$ ) on the XSMT pin, potentially damaging the device.

Providing the divider is set appropriately, any DC voltage can be monitored.

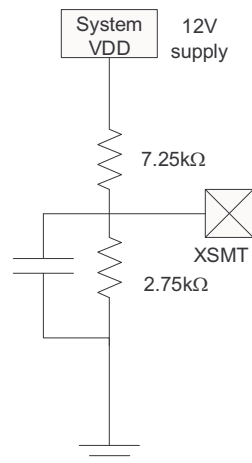

**Figure 78. XSMT in External UVP Mode**

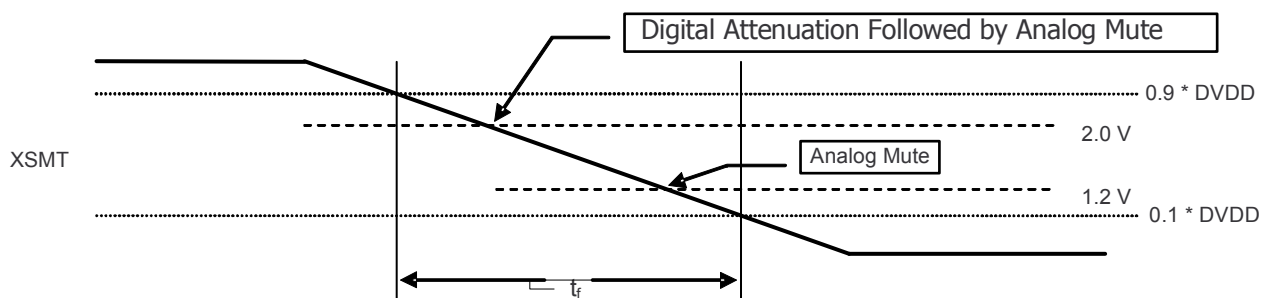

**Figure 79. XSMT Timing for Undervoltage Protection**

## Recommended Powerdown Sequence

With inadequate system design, the PCM514x can exhibit some pop on power down. Pops are caused by the device not having enough time to detect power loss and start the muting process.

The PCM514x evaluation board avoids audible pop with an electrolytic decoupling capacitor. This capacitor provides enough time between data loss from USB or S/PDIF and power supply loss for the muting process to take place.

The PCM514x has two auto-mute functions to mute the device upon power loss (intentional or unintentional).

### XSMT = 0

When the XSMT pin is pulled low, the incoming PCM data is attenuated to 0, closely followed by a hard analog mute. This process takes  $150t_s + 0.2\text{mS}$ .

As this mute time is mainly dominated by the sampling frequency, systems sampling at 192kHz will mute much faster than a 48kHz system.

### Clock Error Detect

When clock error is detected on the incoming data clock, the PCM514x family switches to an internal oscillator, and continues to drive the DAC, while attenuating the data from the last known value. Once this process is complete, the PCM514x outputs will be hard muted to ground.

### Planned Shutdown

These auto-muting processes can be manipulated by system designs to mute before power loss in the following ways:

1. Assert XSMT low  $150t_s + 0.2\text{mS}$  before power is removed.

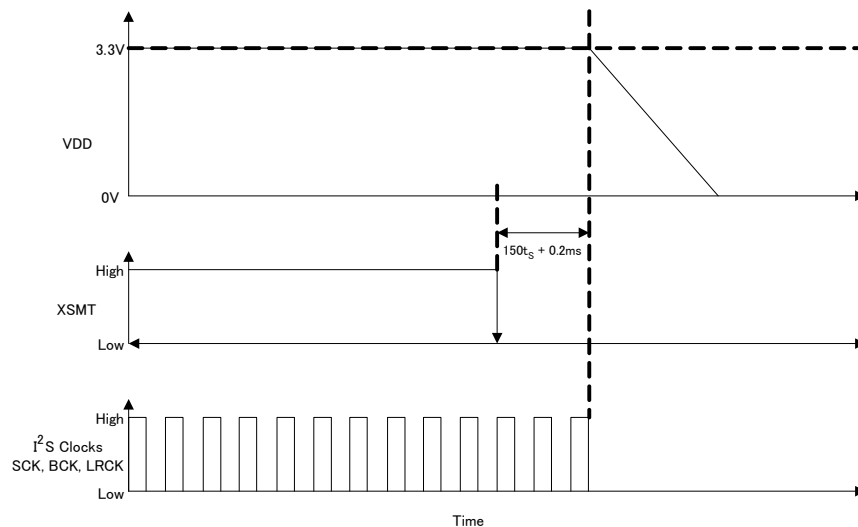

2. Stop I<sup>2</sup>S clocks (SCK, BCK, LRCK) 3ms before powerdown as shown below:

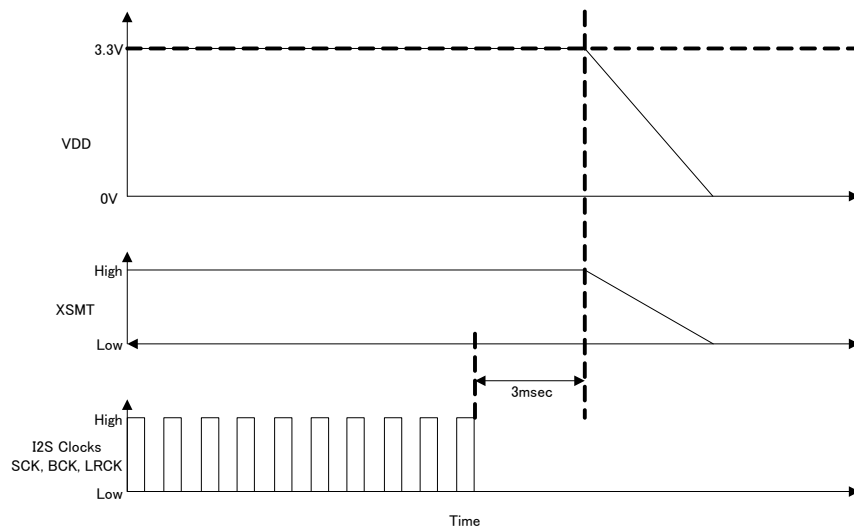

**Unplanned Shutdown**

Many systems use a low-noise regulator to provide an AVDD 3.3V supply for the DAC. The XSMT Pin can take advantage of such a feature to measure the pre-regulated output from the system SMPS to mute the DAC before the entire SMPS discharges. Figure 80 shows how to configure such a system to use the XSMT pin. The XSMT pin can also be used in parallel with a GPIO pin from the system microcontroller/DSP or Power Supply.

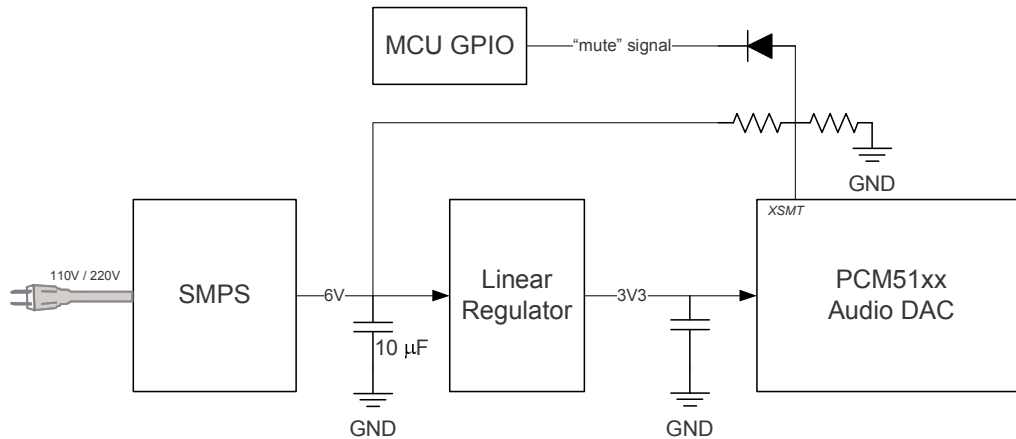

**Figure 80. Using the XSMT Pin**

**Software Control**

**SPI Interface**

The SPI interface is a 4-wire synchronous serial port which operates asynchronously to the serial audio interface and the system clock (SCK). The serial control interface is used to program and read the on-chip mode registers.

The control interface includes MISO (pin 24), MOSI (pin 11), MC (pin 12), and MS (pin 18). MISO (Master In Slave Out) is the serial data output, used to read back the values of the mode registers; MOSI (Master Out Slave In) is the serial data input, used to program the mode registers.

MC is the serial bit clock, used to shift data in and out of the control port by falling edge of MC, and MS is the mode control enable with LOW active, used to enable the internal mode register access. If feedback from the device is not required, the MISO pin can be assigned to GPIO1 by register control.

### Register Read/Write Operation

All read/write operations for the serial control port use 16-bit data words. Figure 81 shows the control data word format. The most significant bit is the read/write bit. For write operations, the bit must be set to 0. For read operations, the bit must be set to 1. There are seven bits, labeled IDX[6:0], that hold the register index (or address) for the read and write operations. The least significant eight bits, D[7:0], contain the data to be written to, or the data that was read from, the register specified by IDX[6:0].

Figure 81 and Figure 82 show the functional timing diagram to write or read through the serial control port. MS is held at a logic-1 state until a register access. To start the register write or read cycle, set MS to logic 0. Sixteen clocks are then provided on MC, corresponding to the 16 bits of the control data word on MOSI and read-back data on MISO. After the eighth clock cycle has completed, the data from the indexed-mode control register appears on MISO during the read operation. After the sixteenth clock cycle has completed, the data is latched into the indexed-mode control register during the write operation. To write or read subsequent data, MS is set to logic 1 once (See  $t_{MHH}$  in Figure 86).

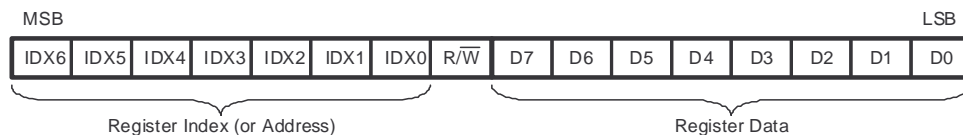

Figure 81. Control Data Word Format; MDI

**NOTE**

B8 is used for selection of “Write” or “Read”. Setting = 0 indicates a “Write”, while = 1 indicates a “Read”. Bits 15–9 are used for register address. Bits 7–0 are used for register data. Multiple-byte write or read (up to 8 bytes) is supported while MS is kept low. The address field becomes the initial address, automatically incrementing for each byte.

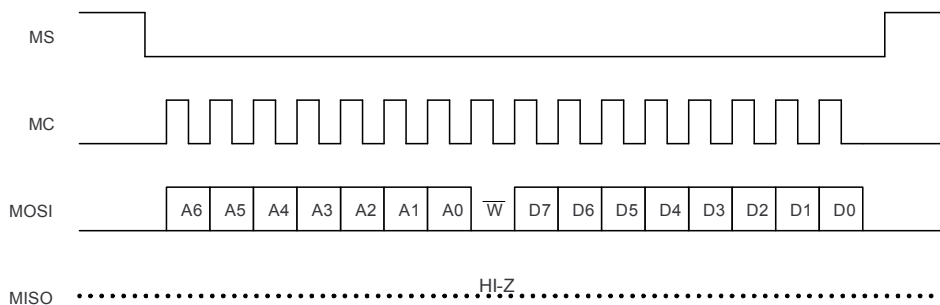

Figure 82. Serial Control Format; Write, Single Byte

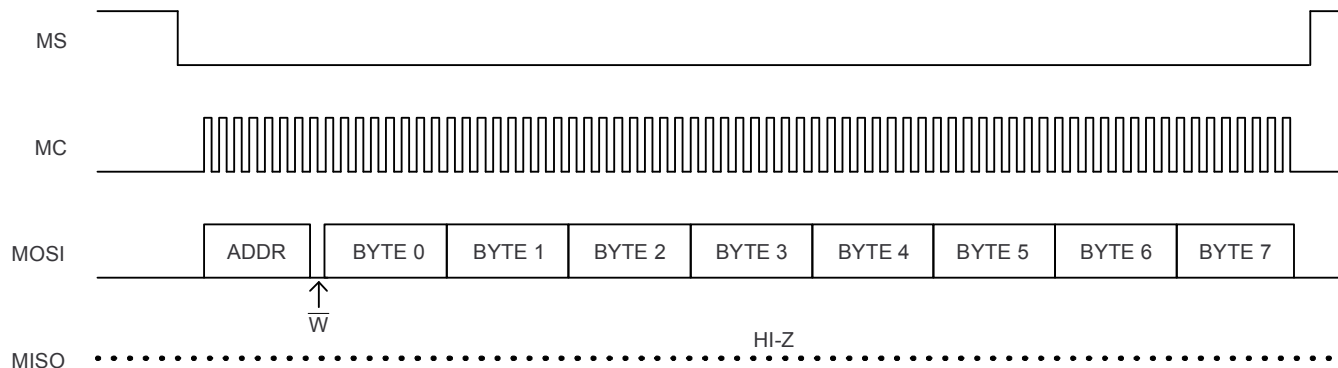

Figure 83. Serial Control Format; Write, Multiple Byte

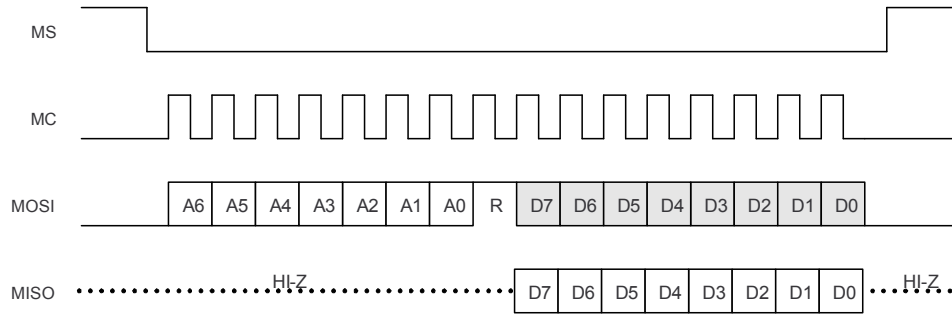

Figure 84. Serial Control Format; Read

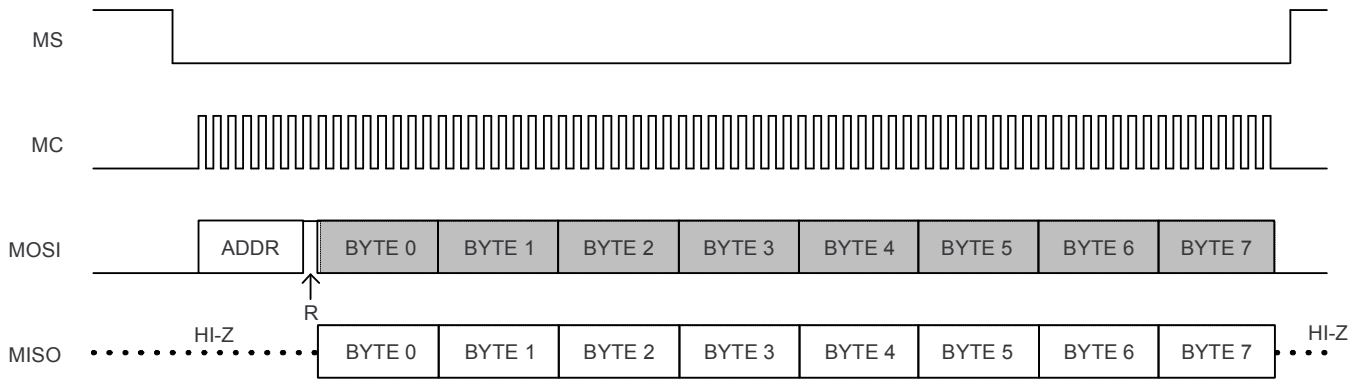

Figure 85. Serial Control Format; Read, Multiple Byte

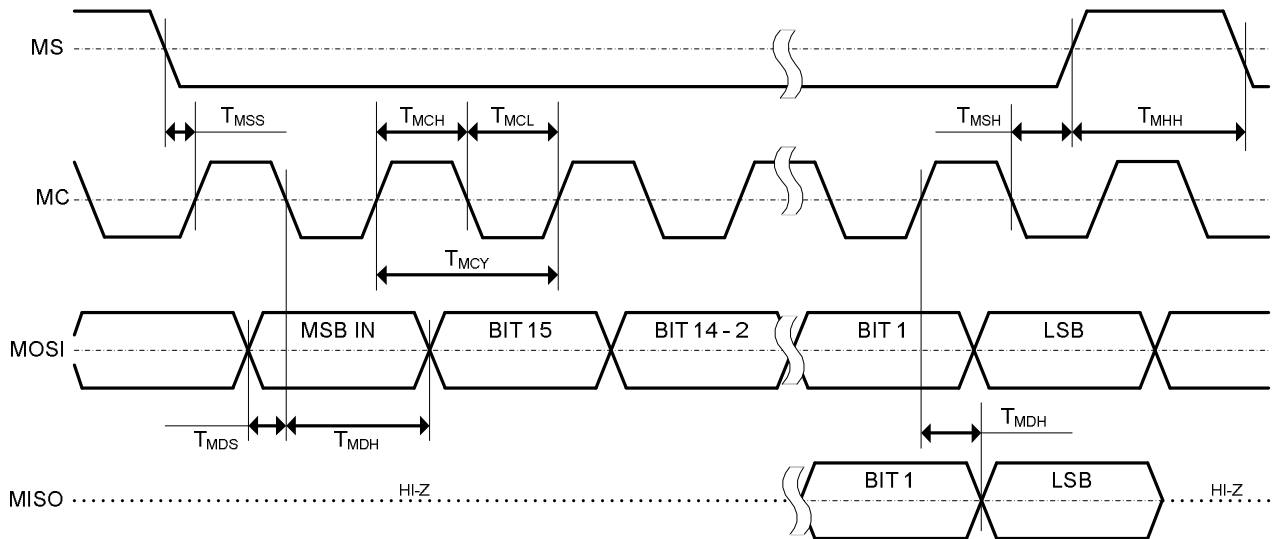

Figure 86. Control Interface Timing

**Table 47. Control Interface Timing**

	Parameters	Min	Max	Units
$t_{MCY}$	MC Pulse Cycle Time	100		ns
$t_{MCL}$	MC Low Level Time	40		
$t_{MCH}$	MC High Level Time	40		
$t_{MHH}$	$\overline{MS}$ High Level Time	20		
$t_{MSS}$	$\overline{MS}$ ↓ Edge to MC ↑ Edge	30		
$t_{MSH}$	$\overline{MS}$ Hold Time <sup>(1)</sup>	30		
$t_{MDH}$	MDI Hold Time	15		
$t_{MDS}$	MDI Set-up Time	15		
$t_{MOS}$	MC Rise Edge to MDO Stable		20	

(1) MC falling edge for LSB to MS rising edge.

### I<sup>2</sup>C Interface

The PCM514x supports the I<sup>2</sup>C serial bus and the data transmission protocol for standard and fast mode as a slave device. This protocol is explained in the I<sup>2</sup>C specification 2.0.

In I<sup>2</sup>C mode, the control terminals are changed as follows.

**Table 48. I<sup>2</sup>C Pins and Functions**

Signal	Pin	I/O	Description
SDA	11	I/O	I <sup>2</sup> C data
SCL	12	I	I <sup>2</sup> C clock
ADR2	16	I	I <sup>2</sup> C address 2
ADR1	24	I	I <sup>2</sup> C address 1

### Slave Address

**Table 49. I<sup>2</sup>C Slave Address**

MSB							LSB
1	0	0	1	1	ADR2	ADR1	R/ $\bar{W}$

The PCM514x has 7 bits for its own slave address. The first five bits (MSBs) of the slave address are factory preset to 10011. The next two bits of the address byte are the device select bits which can be user-defined by the ADR1 and ADR0 terminals. A maximum of four PCM51xxs can be connected on the same bus at one time. Each PCM514x responds when it receives its own slave address.

### Register Address Auto-Increment Mode

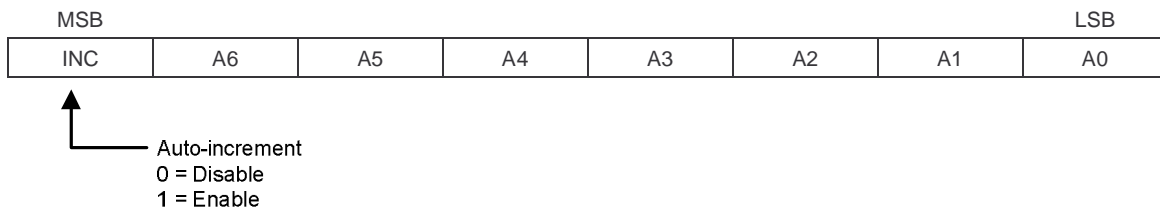
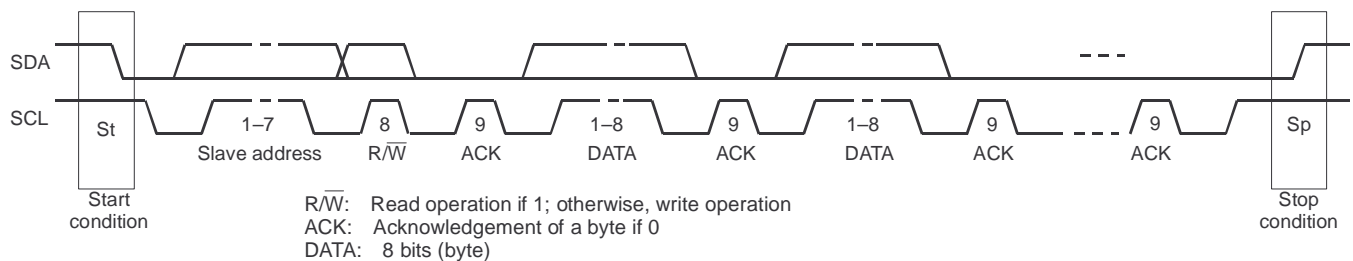

**Figure 87. Auto Increment Mode**

Auto-increment mode allows multiple sequential register locations to be written to or read back in a single operation, and is especially useful for block write and read operations.

### Packet Protocol

A master device must control packet protocol, which consists of start condition, slave address, read/write bit, data if write or acknowledge if read, and stop condition. The PCM514x supports only slave receivers and slave transmitters.



**Figure 88. Packet Protocol**



**Table 50. Write Operation - Basic I<sup>2</sup>C Framework**

Transmitter	M	M	M	S	M	S	M	S		S	M
Data Type	St	slave address	R/	ACK	DATA	ACK	DATA	ACK		ACK	Sp

**Table 51. Read Operation - Basic I<sup>2</sup>C Framework**

Transmitter	M	M	M	S	S	M	S	M		M	M
Data Type	St	slave address	R/	ACK	DATA	ACK	DATA	ACK		NACK	Sp

M = Master Device; S = Slave Device; St = Start Condition Sp = Stop Condition

**Write Register**

A master can write to any PCM514x registers using single or multiple accesses. The master sends a PCM514x slave address with a write bit, a register address with auto-increment bit, and the data. If auto-increment is enabled, the address is that of the starting register, followed by the data to be transferred. When the data is received properly, the index register is incremented by 1 automatically. When the index register reaches 0x7F, the next value is 0x0. Table 52 shows the write operation.

**Table 52. Write Operation**

Transmitter	M	M	M	S	M	S	M	S	M	S		S	M	
Data Type	St	slave addr	W	ACK	inc	reg addr	ACK	write data 1	ACK	write data 2	ACK		ACK	Sp

M = Master Device; S = Slave Device; St = Start Condition Sp = Stop Condition; W = Write; ACK = Acknowledge

**Read Register**

A master can read the PCM514x register. The value of the register address is stored in an indirect index register in advance. The master sends a PCM514x slave address with a read bit after storing the register address. Then the PCM514x transfers the data which the index register points to. When auto-increment is enabled, the index register is incremented by 1 automatically. When the index register reaches 0x7F, the next value is 0x0. Table 53 shows the read operation.

**Table 53. Read Operation**

Transmitter	M	M	M	S	M	S	M	M	M	S	S	M		M	M	
Data Type	St	slave addr	W	ACK	inc	reg addr	ACK	Sr	slave addr	R	ACK	data	ACK		NACK	Sp

M = Master Device; S = Slave Device; St = Start Condition; Sr = Repeated start condition; Sp = Stop Condition; W = Write; R = Read; NACK = Not acknowledge

**Timing Characteristics**

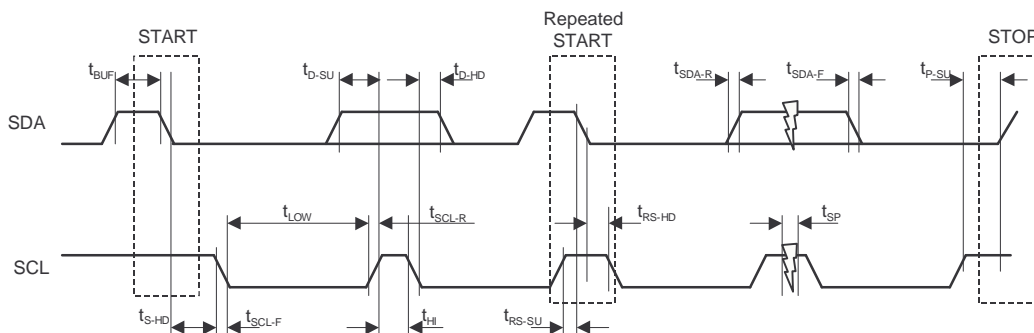

**Figure 89. Register Access Timing**

**Table 54. I<sup>2</sup>C Bus Timing**

SYMBOL	PARAMETER	CONDITIONS	MIN	MAX	UNIT
f <sub>SCL</sub>	SCL clock frequency	Standard		100	kHz
		Fast		400	kHz
t <sub>BUF</sub>	Bus free time between a STOP and START condition	Standard	4.7		μs
		Fast	1.3		
t <sub>LOW</sub>	Low period of the SCL clock	Standard	4.7		μs
		Fast	1.3		
t <sub>HI</sub>	High period of the SCL clock	Standard	4.0		μs
		Fast	600		ns
t <sub>RS-SU</sub>	Setup time for (repeated)START condition	Standard	4.7		μs
		Fast	600		ns
t <sub>S-HD</sub>	Hold time for (repeated)START condition	Standard	4.0		μs
t <sub>RS-HD</sub>		Fast	600		ns
t <sub>D-SU</sub>	Data setup time	Standard	250		ns
		Fast	100		
t <sub>D-HD</sub>	Data hold time	Standard	0	900	ns
		Fast	0	900	
t <sub>SCL-R</sub>	Rise time of SCL signal	Standard	20 + 0.1C <sub>B</sub>	1000	ns
		Fast	20 + 0.1C <sub>B</sub>	300	
t <sub>SCL-R1</sub>	Rise time of SCL signal after a repeated START condition and after an acknowledge bit	Standard	20 + 0.1C <sub>B</sub>	1000	ns
		Fast	20 + 0.1C <sub>B</sub>	300	
t <sub>SCL-F</sub>	Fall time of SCL signal	Standard	20 + 0.1C <sub>B</sub>	1000	ns
		Fast	20 + 0.1C <sub>B</sub>	300	
t <sub>SDA-R</sub>	Rise time of SDA signal	Standard	20 + 0.1C <sub>B</sub>	1000	ns
		Fast	20 + 0.1C <sub>B</sub>	300	
t <sub>SDA-F</sub>	Fall time of SDA signal	Standard	20 + 0.1C <sub>B</sub>	1000	ns
		Fast	20 + 0.1C <sub>B</sub>	300	
t <sub>P-SU</sub>	Setup time for STOP condition	Standard	4.0		μs
		Fast	600		ns
C <sub>B</sub>	Capacitive load for SDA and SCL line			400	pF
t <sub>SP</sub>	Pulse width of spike suppressed	Fast		50	ns
V <sub>NH</sub>	Noise margin at High level for each connected device (including hysteresis)		0.2V <sub>DD</sub>		V

## PCM514x Register Map

In any page, register 0 is the Page Select Register. The register value selects the Register Page from 0 to 255 for next read or write command.

**Table 55. Register Map Summary**

Register Number	Description
<b>Page 0</b>	
0	Control register
1	Analog control register
2	Standby, Powerdown requests
3	Mute
4	PLL Lock Flag, PLL enable
5	Reserved
6	SPI MISO function select
7	De-emphasis enable, SDOUT select
8	GPIO enables
9	BCK, LRCLK configuration
10	DSP GPIO Input
11	Reserved
12	Master mode BCK, LRCLK reset
13	PLL clock source select
14 - 19	Reserved
20 - 24	PLL dividers
25, 26	Reserved
27	DSP clock divider
28	DAC clock divider
29	NCP clock divider
30	OSR clock divider
31	Reserved
32, 33	Master mode dividers
34	$f_s$ speed mode
35, 36	IDAC (number of DSP clock cycles available in one audio frame)
37	Ignore various errors
38,39	Reserved
40, 41	I <sup>2</sup> S configuration
42	DAC data path

**Table 55. Register Map Summary (continued)**

43	DSP program selection
44	Clock missing detection period
59	Auto mute time
60 - 64	Digital volume
65	Auto mute
75 - 79	Reserved
80 - 85	GPIO output selection
86, 87	GPIO control
88, 89	Reserved
90	DSP overflow
91 - 94	Sample rate status
95 - 107	Reserved
108	Analog mute monitor
109 - 118	Reserved
119	GPIO input
120	Auto Mute flags
<b>Page 1</b>	
1	Output amplitude type
2	Analog gain control
3, 4	Reserved
5	Undervoltage protection
6	Analog mute control
7	Analog gain boost
8, 9	VCOM configuration
<b>Page 44</b>	
1	Coefficient memory (CRAM) control
Pages 44 - 52	Coefficient buffer - A (256 coeffs x 24 bits) : See <a href="#">Table 56</a>
Pages 66 - 74	Coefficient buffer - B (256 coeffs x 24 bits) : See <a href="#">Table 57</a>
Pages 152 - 186	Instruction buffer (1024 instruction x 25 bits), I512 - I1023 are reserved.: See <a href="#">Table 58</a>
Pages 187 - 255	Reserved

**Table 56. Coefficient Buffer-A Map**

Coeff NO	Page NO	Base Register	Base Register+0	Base Register+1	Base Register+2	Base Register+3
C0	44	8	Coef(23:16)	Coef(15:8)	Coef(7:0)	Reserved.
C1	44	12	Coef(23:16)	Coef(15:8)	Coef(7:0)	Reserved.
..	..	..	..	..	..	..
C29	44	124	Coef(23:16)	Coef(15:8)	Coef(7:0)	Reserved.
C30	45	8	Coef(23:16)	Coef(15:8)	Coef(7:0)	Reserved.
..	..	..	..	..	..	..
C59	45	124	Coef(23:16)	Coef(15:8)	Coef(7:0)	Reserved.
C60	46	8	Coef(23:16)	Coef(15:8)	Coef(7:0)	Reserved.
..	..	..	..	..	..	..

**Table 56. Coefficient Buffer-A Map (continued)**

C89	46	124	Coef(23:16)	Coef(15:8)	Coef(7:0)	Reserved.
C90	47	8	Coef(23:16)	Coef(15:8)	Coef(7:0)	Reserved.
..	..	..	..	..	..	..
C119	47	124	Coef(23:16)	Coef(15:8)	Coef(7:0)	Reserved.
C120	48	8	Coef(23:16)	Coef(15:8)	Coef(7:0)	Reserved.
..	..	..	..	..	..	..
C149	48	124	Coef(23:16)	Coef(15:8)	Coef(7:0)	Reserved.
C150	49	8	Coef(23:16)	Coef(15:8)	Coef(7:0)	Reserved.
..	..	..	..	..	..	..
C179	49	124	Coef(23:16)	Coef(15:8)	Coef(7:0)	Reserved.
C180	50	8	Coef(23:16)	Coef(15:8)	Coef(7:0)	Reserved.
..	..	..	..	..	..	..
C209	50	124	Coef(23:16)	Coef(15:8)	Coef(7:0)	Reserved.
C210	51	8	Coef(23:16)	Coef(15:8)	Coef(7:0)	Reserved.
..	..	..	..	..	..	..
C239	51	124	Coef(23:16)	Coef(15:8)	Coef(7:0)	Reserved.
C240	52	8	Coef(23:16)	Coef(15:8)	Coef(7:0)	Reserved.
..	..	..	..	..	..	..
C255	52	68	Coef(23:16)	Coef(15:8)	Coef(7:0)	Reserved.

**Table 57. Coefficient Buffer-B Map**

Coeff NO	Page NO	Base Register	Base Register+0	Base Register+1	Base Register+2	Base Register+3
C0	62	8	Coef(23:16)	Coef(15:8)	Coef(7:0)	Reserved.
C1	62	12	Coef(23:16)	Coef(15:8)	Coef(7:0)	Reserved.
..	..	..	..	..	..	..
C29	62	124	Coef(23:16)	Coef(15:8)	Coef(7:0)	Reserved.
C30	63	8	Coef(23:16)	Coef(15:8)	Coef(7:0)	Reserved.
..	..	..	..	..	..	..
C59	63	124	Coef(23:16)	Coef(15:8)	Coef(7:0)	Reserved.
C60	64	8	Coef(23:16)	Coef(15:8)	Coef(7:0)	Reserved.
..	..	..	..	..	..	..
C89	64	124	Coef(23:16)	Coef(15:8)	Coef(7:0)	Reserved.
C90	65	8	Coef(23:16)	Coef(15:8)	Coef(7:0)	Reserved.
..	..	..	..	..	..	..
C119	65	124	Coef(23:16)	Coef(15:8)	Coef(7:0)	Reserved.
C120	66	8	Coef(23:16)	Coef(15:8)	Coef(7:0)	Reserved.
..	..	..	..	..	..	..
C149	66	124	Coef(23:16)	Coef(15:8)	Coef(7:0)	Reserved.
C150	67	8	Coef(23:16)	Coef(15:8)	Coef(7:0)	Reserved.
..	..	..	..	..	..	..
C179	67	124	Coef(23:16)	Coef(15:8)	Coef(7:0)	Reserved.
C180	68	8	Coef(23:16)	Coef(15:8)	Coef(7:0)	Reserved.
..	..	..	..	..	..	..
C209	68	124	Coef(23:16)	Coef(15:8)	Coef(7:0)	Reserved.
C210	69	8	Coef(23:16)	Coef(15:8)	Coef(7:0)	Reserved.
..	..	..	..	..	..	..
C239	69	124	Coef(23:16)	Coef(15:8)	Coef(7:0)	Reserved.
C240	70	8	Coef(23:16)	Coef(15:8)	Coef(7:0)	Reserved.

**Table 57. Coefficient Buffer-B Map (continued)**

..	..	..	..	..	..	..
C255	70	68	Coef(23:16)	Coef(15:8)	Coef(7:0)	Reserved.

**Table 58. miniDSP Instruction Map**

Coeff NO	Page NO	Base Register	Base Register+0	Base Register+1	Base Register+2	Base Register+3
I0	152	8	Instr(31:24)	Instr(23:16)	Instr(15:8)	Instr(7:0)
I1	152	12	Instr(31:24)	Instr(23:16)	Instr(15:8)	Instr(7:0)
..	..	..	..	..	..	..
I29	152	124	Instr(31:24)	Instr(23:16)	Instr(15:8)	Instr(7:0)
I30	153	8	Instr(31:24)	Instr(23:16)	Instr(15:8)	Instr(7:0)
..	..	..	..	..	..	..
I59	153	124	Instr(31:24)	Instr(23:16)	Instr(15:8)	Instr(7:0)
I60	154	8	Instr(31:24)	Instr(23:16)	Instr(15:8)	Instr(7:0)
..	..	..	..	..	..	..
I89	154	124	Instr(31:24)	Instr(23:16)	Instr(15:8)	Instr(7:0)
I90	155	8	Instr(31:24)	Instr(23:16)	Instr(15:8)	Instr(7:0)
..	..	..	..	..	..	..
I119	155	124	Instr(31:24)	Instr(23:16)	Instr(15:8)	Instr(7:0)
I120	156	8	Instr(31:24)	Instr(23:16)	Instr(15:8)	Instr(7:0)
..	..	..	..	..	..	..
I149	156	124	Instr(31:24)	Instr(23:16)	Instr(15:8)	Instr(7:0)
I150	157	8	Instr(31:24)	Instr(23:16)	Instr(15:8)	Instr(7:0)
..	..	..	..	..	..	..
I179	157	124	Instr(31:24)	Instr(23:16)	Instr(15:8)	Instr(7:0)
I180	158	8	Instr(31:24)	Instr(23:16)	Instr(15:8)	Instr(7:0)
..	..	..	..	..	..	..
I209	158	124	Instr(31:24)	Instr(23:16)	Instr(15:8)	Instr(7:0)
I210	159	8	Instr(31:24)	Instr(23:16)	Instr(15:8)	Instr(7:0)
..	..	..	..	..	..	..
I239	159	124	Instr(31:24)	Instr(23:16)	Instr(15:8)	Instr(7:0)
I240	160	8	Instr(31:24)	Instr(23:16)	Instr(15:8)	Instr(7:0)
..	..	..	..	..	..	..
I269	160	124	Instr(31:24)	Instr(23:16)	Instr(15:8)	Instr(7:0)
I270	161	8	Instr(31:24)	Instr(23:16)	Instr(15:8)	Instr(7:0)
..	..	..	..	..	..	..
I299	161	124	Instr(31:24)	Instr(23:16)	Instr(15:8)	Instr(7:0)
I300	162	8	Instr(31:24)	Instr(23:16)	Instr(15:8)	Instr(7:0)
..	..	..	..	..	..	..
I329	162	124	Instr(31:24)	Instr(23:16)	Instr(15:8)	Instr(7:0)
I330	163	8	Instr(31:24)	Instr(23:16)	Instr(15:8)	Instr(7:0)
..	..	..	..	..	..	..
I359	163	124	Instr(31:24)	Instr(23:16)	Instr(15:8)	Instr(7:0)
I360	164	8	Instr(31:24)	Instr(23:16)	Instr(15:8)	Instr(7:0)
..	..	..	..	..	..	..
I389	164	124	Instr(31:24)	Instr(23:16)	Instr(15:8)	Instr(7:0)
I390	165	8	Instr(31:24)	Instr(23:16)	Instr(15:8)	Instr(7:0)
..	..	..	..	..	..	..
I419	165	124	Instr(31:24)	Instr(23:16)	Instr(15:8)	Instr(7:0)

**Table 58. miniDSP Instruction Map (continued)**

I420	166	8	Instr(31:24)	Instr(23:16)	Instr(15:8)	Instr(7:0)
..	..	..	..	..	..	..
I449	166	124	Instr(31:24)	Instr(23:16)	Instr(15:8)	Instr(7:0)
I450	167	8	Instr(31:24)	Instr(23:16)	Instr(15:8)	Instr(7:0)
..	..	..	..	..	..	..
I479	167	124	Instr(31:24)	Instr(23:16)	Instr(15:8)	Instr(7:0)
I480	168	8	Instr(31:24)	Instr(23:16)	Instr(15:8)	Instr(7:0)
..	..	..	..	..	..	..
I509	168	124	Instr(31:24)	Instr(23:16)	Instr(15:8)	Instr(7:0)
I510	169	8	Instr(31:24)	Instr(23:16)	Instr(15:8)	Instr(7:0)
I511	169	12	Instr(31:24)	Instr(23:16)	Instr(15:8)	Instr(7:0)
..	..	..	..	..	..	..
I539	169	124	Reserved.	Reserved.	Reserved.	Reserved.
I540	170	8	Reserved.	Reserved.	Reserved.	Reserved.
..	..	..	..	..	..	..
I569	170	124	Reserved.	Reserved.	Reserved.	Reserved.
I570	171	8	Reserved.	Reserved.	Reserved.	Reserved.
..	..	..	..	..	..	..
I599	171	124	Reserved.	Reserved.	Reserved.	Reserved.
I600	172	8	Reserved.	Reserved.	Reserved.	Reserved.
..	..	..	..	..	..	..
I629	172	124	Reserved.	Reserved.	Reserved.	Reserved.
I630	173	8	Reserved.	Reserved.	Reserved.	Reserved.
..	..	..	..	..	..	..
I659	173	124	Reserved.	Reserved.	Reserved.	Reserved.
I660	174	8	Reserved.	Reserved.	Reserved.	Reserved.
..	..	..	..	..	..	..
I689	174	124	Reserved.	Reserved.	Reserved.	Reserved.
I690	175	8	Reserved.	Reserved.	Reserved.	Reserved.
..	..	..	..	..	..	..
I719	175	124	Reserved.	Reserved.	Reserved.	Reserved.
I720	176	8	Reserved.	Reserved.	Reserved.	Reserved.
..	..	..	..	..	..	..
I749	176	124	Reserved.	Reserved.	Reserved.	Reserved.
I750	177	8	Reserved.	Reserved.	Reserved.	Reserved.
..	..	..	..	..	..	..
I779	177	124	Reserved.	Reserved.	Reserved.	Reserved.
I780	178	8	Reserved.	Reserved.	Reserved.	Reserved.
..	..	..	..	..	..	..
I809	178	124	Reserved.	Reserved.	Reserved.	Reserved.
I810	179	8	Reserved.	Reserved.	Reserved.	Reserved.
..	..	..	..	..	..	..
I839	179	124	Reserved.	Reserved.	Reserved.	Reserved.
I840	180	8	Reserved.	Reserved.	Reserved.	Reserved.
..	..	..	..	..	..	..
I869	180	124	Reserved.	Reserved.	Reserved.	Reserved.
I870	181	8	Reserved.	Reserved.	Reserved.	Reserved.
..	..	..	..	..	..	..

**Table 58. miniDSP Instruction Map (continued)**

I899	181	124	Reserved.	Reserved.	Reserved.	Reserved.
I900	182	8	Reserved.	Reserved.	Reserved.	Reserved.
..	..	..	..	..	..	..
I929	182	124	Reserved.	Reserved.	Reserved.	Reserved.
I930	183	8	Reserved.	Reserved.	Reserved.	Reserved.
..	..	..	..	..	..	..
I959	183	124	Reserved.	Reserved.	Reserved.	Reserved.
I960	184	8	Reserved.	Reserved.	Reserved.	Reserved.
..	..	..	..	..	..	..
I989	184	124	Reserved.	Reserved.	Reserved.	Reserved.
I990	185	8	Reserved.	Reserved.	Reserved.	Reserved.
..	..	..	..	..	..	..
I1019	185	124	Reserved.	Reserved.	Reserved.	Reserved.
I1020	186	8	Reserved.	Reserved.	Reserved.	Reserved.
..	..	..	..	..	..	..
I1023	186	20	Reserved.	Reserved.	Reserved.	Reserved.

Detailed Register Descriptions

Page 0 / Register 1

Dec	Hex	b7	b6	b5	b4	b3	b2	b1	b0
1	01	RSV	RSV	RSV	RSTM	RSV	RSV	RSV	RSTR
Reset Value					0				0

<b>RSV</b>	<b>Reserved</b> Reserved. Do not access.
<b>RSTM</b>	<b>Reset Modules</b> This bit resets the interpolation filter and the DAC modules. Since the DSP is also reset, the coefficient RAM content will also be cleared by the DSP. This bit is auto cleared and can be set only in standby mode. Default value: 0 0: Normal 1: Reset modules
<b>RSTR</b>	<b>Reset Registers</b> This bit resets the mode registers back to their initial values. The RAM content is not cleared, but the execution source will be back to ROM. This bit is auto cleared and must be set only when the DAC is in standby mode (resetting registers when the DAC is running is prohibited and not supported). Default value: 0 0: Normal 1: Reset mode registers

Page 0 / Register 2

Dec	Hex	b7	b6	b5	b4	b3	b2	b1	b0
2	02	RSV	RSV	RSV	RQST	RSV	RSV	RSV	RQPD
Reset Value					0				0

<b>RSV</b>	<b>Reserved</b> Reserved. Do not access.
<b>RQST</b>	<b>Standby Request</b> When this bit is set, the DAC is forced into system standby mode, which is also the mode the system enters in case of clock errors. In this mode, most subsystems are powered down except for the charge pump and digital power supply. Default value: 0 0: Normal operation 1: Standby mode
<b>RQPD</b>	<b>Powerdown Request</b> Setting RQPD sends the DAC into powerdown mode, reducing power consumption to a minimum. The charge pump also powers down. However, it takes longer to restart from this mode. Powerdown mode has higher precedence than standby mode; setting this bit along with bit 4 for standby mode sends the DAC into powerdown mode. Default value: 0 0: Normal operation 1: Powerdown mode

Page 0 / Register 3

Dec	Hex	b7	b6	b5	b4	b3	b2	b1	b0
3	03	RSV	RSV	RSV	RQML	RSV	RSV	RSV	RQMR
Reset Value					0				0



<b>RSV</b>	<b>Reserved</b> Reserved. Do not access.
<b>RQML</b>	<b>Mute Left Channel</b> This bit issues soft mute request for the left channel. The volume will be smoothly ramped down or up to avoid pop or click noise.  Default value: 0 0: Normal volume 1: Mute
<b>RQMR</b>	<b>Mute Right Channel</b> This bit issues soft mute request for the right channel. The volume will be smoothly ramped down or up to avoid pop or click noise.  Default value: 0 0: Normal volume 1: Mute

**Page 0 / Register 4**

Dec	Hex	b7	b6	b5	b4	b3	b2	b1	b0
4	04	RSV	RSV	RSV	PLCK	RSV	RSV	RSV	PLLE
Reset Value									1

<b>RSV</b>	<b>Reserved</b> Reserved. Do not access.
<b>PLCK</b>	<b>PLL Lock Flag (Read Only)</b> This bit indicates whether the PLL is locked or not. When the PLL is disabled this bit always shows that the PLL is not locked. 0: The PLL is locked  1: The PLL is not locked
<b>PLLE</b>	<b>PLL Enable</b> This bit enables or disables the internal PLL. When PLL is disabled, the master clock will be switched to the SCK.  Default value: 1 0: Disable PLL 1: Enable PLL

**Page 0 / Register 6**

Dec	Hex	b7	b6	b5	b4	b3	b2	b1	b0
6	06	RSV	RSV	RSV	RSV	RSV	RSV	FSMI1	FSMI0
Reset Value								0	0

<b>RSV</b>	<b>Reserved</b> Reserved. Do not access.
<b>FSMI[1:0]</b>	<b>SPI MISO function sel</b> These bits select the function of the SPI_MISO pin when in SPI mode. If the pin is set as GPIO, register readout via SPI is not possible.  Default value: 00 00: SPI_MISO 01: GPIO1 Others: Reserved (Do not set)

**Page 0 / Register 7**

Dec	Hex	b7	b6	b5	b4	b3	b2	b1	b0
7	07	RSV	RSV	RSV	DEMP	RSV	RSV	RSV	SDSL
Reset Value					0				0

<b>RSV</b>	<b>Reserved</b> Reserved. Do not access.
<b>DEMP</b>	<b>De-Emphasis Enable</b> This bit enables or disables the de-emphasis filter. The default coefficients are for 44.1kHz sampling rate, but can be changed by reprogramming the appropriate coefficients in RAM. Default value: 0 0: De-emphasis filter is disabled 1: De-emphasis filter is enabled
<b>SDSL</b>	<b>SDOUT Select</b> This bit selects what is being output as SDOOUT via GPIO pins. Default value: 0 0: SDOOUT is the DSP output (post-processing) 1: SDOOUT is the DSP input (pre-processing)

**Page 0 / Register 8**

Dec	Hex	b7	b6	b5	b4	b3	b2	b1	b0
8	08	RSV	RSV	G6OE	G5OE	G4OE	G3OE	G2OE	G1OE
Reset Value				0	0	0	0	0	0

<b>RSV</b>	<b>Reserved</b> Reserved. Do not access.
<b>G6OE</b>	<b>GPIO6 Output Enable</b> This bit sets the direction of the GPIO6 pin Default value: 0 0: GPIO6 is input 1: GPIO6 is output
<b>G5OE</b>	<b>GPIO5 Output Enable</b> This bit sets the direction of the GPIO5 pin Default value: 0 0: GPIO5 is input 1: GPIO5 is output
<b>G4OE</b>	<b>GPIO4 Output Enable</b> This bit sets the direction of the GPIO4 pin Default value: 0 0: GPIO4 is input 1: GPIO4 is output
<b>G3OE</b>	<b>GPIO3 Output Enable</b> This bit sets the direction of the GPIO3 pin Default value: 0 0: GPIO3 is input 1: GPIO3 is output
<b>G2OE</b>	<b>GPIO2 Output Enable</b> This bit sets the direction of the GPIO2 pin Default value: 0

	0: GPIO2 is input 1: GPIO2 is output
<b>G1OE</b>	<b>GPIO1 Output Enable</b> This bit sets the direction of the GPIO1 pin Default value: 0 0: GPIO1 is input 1: GPIO1 is output

**Page 0 / Register 9**

Dec	Hex	b7	b6	b5	b4	b3	b2	b1	b0
9	09	RSV	RSV	BCKP	BCKO	RSV	RSV	RSV	LRKO
Reset Value				0	0				0

<b>RSV</b>	<b>Reserved</b> Reserved. Do not access.
<b>BCKP</b>	<b>BCK Polarity</b> This bit sets the inverted BCK mode. In inverted BCK mode, the DAC assumes that the LRCK and DIN edges are aligned to the rising edge of the BCK. Normally they are assumed to be aligned to the falling edge of the BCK. Default value: 0 0: Normal BCK mode 1: Inverted BCK mode
<b>BCKO</b>	<b>BCK Output Enable</b> This bit sets the BCK pin direction to output for I <sup>2</sup> S master mode operation. In I <sup>2</sup> S master mode the PCM51xx outputs the reference BCK and LRCK, and the external source device provides the DIN according to these clocks. Use Page 0 / Register 32 to program the division factor of the SCK to yield the desired BCK rate (normally 64f <sub>s</sub> ) Default value: 0 0: BCK is input (I <sup>2</sup> S slave mode) 1: BCK is output (I <sup>2</sup> S master mode)
<b>LRKO</b>	<b>LRCLK Output Enable</b> This bit sets the LRCK pin direction to output for I <sup>2</sup> S master mode operation. In I <sup>2</sup> S master mode the PCM51xx outputs the reference BCK and LRCK, and the external source device provides the DIN according to these clocks. Use Page 0 / Register 33 to program the division factor of the BCK to yield 1f <sub>s</sub> for LRCK. Default value: 0 0: LRCK is input (I <sup>2</sup> S slave mode) 1: LRCK is output (I <sup>2</sup> S master mode)

**Page 0 / Register 10**

Dec	Hex	b7	b6	b5	b4	b3	b2	b1	b0
10	0A	DSPG7	DSPG6	DSPG5	DSPG4	DSPG3	DSPG2	DSPG1	DSPG0
Reset Value		0	0	0	0	0	0	0	0

<b>DSPG[7:0]</b>	<b>DSP GPIO Input</b> The DSP accepts a 24-bit external control signals input. The value set in this register will go to bit 16:8 of this external input. Default value: 00000000
------------------	---

**Page 0 / Register 12**

Dec	Hex	b7	b6	b5	b4	b3	b2	b1	b0
12	0C	RSV	RSV	RSV	RSV	RSV	RSV	RBCK	RLRK
Reset Value								0	0

<b>RSV</b>	<b>Reserved</b> Reserved. Do not access.
<b>RBCK</b>	<b>Master Mode BCK Divider Reset</b> This bit, when set to 0, will reset the SCK divider to generate BCK clock for I <sup>2</sup> S master mode. To use I <sup>2</sup> S master mode, the divider must be enabled and programmed properly. Default value: 0 0: Master mode BCK clock divider is reset 1: Master mode BCK clock divider is functional
<b>RLRK</b>	<b>Master Mode LRCK Divider Reset</b> This bit, when set to 0, will reset the BCK divider to generate LRCK clock for I <sup>2</sup> S master mode. To use I <sup>2</sup> S master mode, the divider must be enabled and programmed properly. Default value: 0 0: Master mode LRCK clock divider is reset 1: Master mode LRCK clock divider is functional

**Page 0 / Register 13**

Dec	Hex	b7	b6	b5	b4	b3	b2	b1	b0
13	0D	RSV	RSV	RSV	SREF	RSV	RSV	RSV	RSV
Reset Value					0				

<b>RSV</b>	<b>Reserved</b> Reserved. Do not access.
<b>SREF</b>	<b>PLL Reference</b> This bit select the source clock for internal PLL. This bit is ignored and overridden in clock auto set mode. Default value: 0 0: The PLL reference clock is SCK 1: The PLL reference clock is BCK

**Page 0 / Register 20**

Dec	Hex	b7	b6	b5	b4	b3	b2	b1	b0
20	14	RSV	RSV	RSV	RSV	PPDV3	PPDV2	PPDV1	PPDV0
Reset Value						0	0	0	0

<b>RSV</b>	<b>Reserved</b> Reserved. Do not access.
<b>PPDV[3:0]</b>	<b>PLL P</b> These bits set the PLL divider P factor. These bits are ignored in clock auto set mode. Default value: 0000 0000: P=1 0001: P=2 ... 1110: P=15 1111: Prohibited (do not set this value)

**Page 0 / Register 21**

Dec	Hex	b7	b6	b5	b4	b3	b2	b1	b0
21	15	RSV	RSV	PJDV5	PJDV4	PJDV3	PJDV2	PJDV1	PJDV0
Reset Value				0	0	0	0	0	0

<b>RSV</b>	<b>Reserved</b> Reserved. Do not access.
<b>PJDV[5:0]</b>	<b>PLL J</b> These bits set the J part of the overall PLL multiplication factor J.D * R. These bits are ignored in clock auto set mode.  Default value: 000000 000000: Prohibited (do not set this value) 000001: J=1 000010: J=2 ... 111111: J=63

**Page 0 / Register 22**

Dec	Hex	b7	b6	b5	b4	b3	b2	b1	b0
22	16	RSV	RSV	PDDV13	PDDV12	PDDV11	PDDV10	PDDV9	PDDV8
Reset Value				0	0	0	0	0	0

**Page 0 / Register 23**

23	17	PDDV7	PDDV6	PDDV5	PDDV4	PDDV3	PDDV2	PDDV1	PDDV0
Reset Value		0	0	0	0	0	0	0	0

<b>RSV</b>	<b>Reserved</b> Reserved. Do not access.
<b>PDDV[13:0]</b>	<b>PLL D (MSB)</b> These bits set the D part of the overall PLL multiplication factor J.D * R. These bits are ignored in clock auto set mode.  Default value: 00000000000000 0 (in decimal): D=0000 1 (in decimal): D=0001 ... 9999 (in decimal): D=9999 others: Prohibited (do not set)

**Page 0 / Register 24**

Dec	Hex	b7	b6	b5	b4	b3	b2	b1	b0
24	18	RSV	RSV	RSV	RSV	PRDV3	PRDV2	PRDV1	PRDV0
Reset Value						0	0	0	0

<b>RSV</b>	<b>Reserved</b> Reserved. Do not access.
<b>PRDV[3:0]</b>	<b>PLL R</b> These bits set the R part of the overall PLL multiplication factor J.D * R. These bits are ignored in clock auto set mode.  Default value: 0000 0000: R=1 0001: R=2 ... 1111: R=16

**Page 0 / Register 27**

Dec	Hex	b7	b6	b5	b4	b3	b2	b1	b0
27	1B	RSV	DDSP6	DDSP5	DDSP4	DDSP3	DDSP2	DDSP1	DDSP0
Reset Value			0	0	0	0	0	0	0

<b>RSV</b>	<b>Reserved</b> Reserved. Do not access.
<b>DDSP[6:0]</b>	<b>DSP Clock Divider</b> These bits set the source clock divider value for the DSP clock. These bits are ignored in clock auto set mode. Default value: 0000000 0000000: Divide by 1 0000001: Divide by 2 ... 1111111: Divide by 128

**Page 0 / Register 28**

Dec	Hex	b7	b6	b5	b4	b3	b2	b1	b0
28	1C	RSV	DDAC6	DDAC5	DDAC4	DDAC3	DDAC2	DDAC1	DDAC0
Reset Value			0	0	0	0	0	0	0

<b>RSV</b>	<b>Reserved</b> Reserved. Do not access.
<b>DDAC[6:0]</b>	<b>DAC Clock Divider</b> These bits set the source clock divider value for the DAC clock. These bits are ignored in clock auto set mode. Default value: 0000000 0000000: Divide by 1 0000001: Divide by 2 ... 1111111: Divide by 128

**Page 0 / Register 29**

Dec	Hex	b7	b6	b5	b4	b3	b2	b1	b0
29	1D	RSV	DNCP6	DNCP5	DNCP4	DNCP3	DNCP2	DNCP1	DNCP0
Reset Value			0	0	0	0	0	0	0

<b>RSV</b>	<b>Reserved</b> Reserved. Do not access.
<b>DNCP[6:0]</b>	<b>NCP Clock Divider</b> These bits set the source clock divider value for the CP clock. These bits are ignored in clock auto set mode. Default value: 0000000 0000000: Divide by 1 0000001: Divide by 2 ... 1111111: Divide by 128

**Page 0 / Register 30**

Dec	Hex	b7	b6	b5	b4	b3	b2	b1	b0
30	1E	RSV	DOSR6	DOSR5	DOSR4	DOSR3	DOSR2	DOSR1	DOSR0
Reset Value			0	0	0	0	0	0	0

<b>RSV</b>	<b>Reserved</b> Reserved. Do not access.
<b>DOSR[6:0]</b>	<b>OSR Clock Divider</b> These bits set the source clock divider value for the OSR clock. These bits are ignored in clock auto set mode. Default value: 0000000 0000000: Divide by 1 0000001: Divide by 2 ... 1111111: Divide by 128

**Page 0 / Register 32**

Dec	Hex	b7	b6	b5	b4	b3	b2	b1	b0
32	20	RSV	DBCK6	DBCK5	DBCK4	DBCK3	DBCK2	DBCK1	DBCK0
Reset Value			0	0	0	0	0	0	0

<b>RSV</b>	<b>Reserved</b> Reserved. Do not access.
<b>DBCK[6:0]</b>	<b>Master Mode BCK Divider</b> These bits set the SCK divider value to generate I <sup>2</sup> S master BCK clock. Default value: 0000000 0000000: Divide by 1 0000001: Divide by 2 ... 1111111: Divide by 128

**Page 0 / Register 33**

Dec	Hex	b7	b6	b5	b4	b3	b2	b1	b0
33	21	DLRK7	DLRK6	DLRK5	DLRK4	DLRK3	DLRK2	DLRK1	DLRK0
Reset Value		0	0	0	0	0	0	0	0

<b>DLRK[7:0]</b>	<b>Master Mode LRCK Divider</b> These bits set the I <sup>2</sup> S master BCK clock divider value to generate I <sup>2</sup> S master LRCK clock. Default value: 00000000 00000000: Divide by 1 00000001: Divide by 2 ... 11111111: Divide by 256
------------------	--

**Page 0 / Register 34**

Dec	Hex	b7	b6	b5	b4	b3	b2	b1	b0
34	22	RSV	RSV	RSV	I16E	RSV	RSV	FSSP1	FSSP0
Reset Value					0			0	0

<b>RSV</b>	<b>Reserved</b> Reserved. Do not access.
<b>I16E</b>	<b>16x Interpolation</b> This bit enables or disables the 16x interpolation mode Default value: 0 0: 8x interpolation 1: 16x interpolation

<b>FSSP[1:0]</b>	<p><b><math>f_S</math> Speed Mode</b></p> <p>These bits select the <math>f_S</math> operation mode, which must be set according to the current audio sampling rate. These bits are ignored in clock auto set mode.</p> <p>Default value: 00</p> <p>00: Single speed (<math>f_S = 48</math> kHz)</p> <p>01: Double speed (<math>48</math> kHz &lt; <math>f_S = 96</math> kHz)</p> <p>10: Quad speed (<math>96</math> kHz &lt; <math>f_S = 192</math> kHz)</p> <p>11: Octal speed (<math>192</math> kHz &lt; <math>f_S = 384</math> kHz)</p>
------------------	--

**Page 0 / Register 35**

Dec	Hex	b7	b6	b5	b4	b3	b2	b1	b0
35	23	IDAC15	IDAC14	IDAC13	IDAC12	IDAC11	IDAC10	IDAC9	IDAC8
Reset Value		0	0	0	0	0	0	0	1

**Page 0 / Register 36**

Dec	Hex	b7	b6	b5	b4	b3	b2	b1	b0
36	24	IDAC7	IDAC6	IDAC5	IDAC4	IDAC3	IDAC2	IDAC1	IDAC0
Reset Value		0	0	0	0	0	0	0	0

<b>IDAC[15:0]</b>	<p><b>IDAC (MSB)</b></p> <p>These bits specify the number of DSP clock cycles available in one audio frame. The value should match the DSP clock <math>f_S</math> ratio. These bits are ignored in clock auto set mode.</p> <p>Default value: 0000000100000000</p>
-------------------	--

**Page 0 / Register 37**

Dec	Hex	b7	b6	b5	b4	b3	b2	b1	b0
37	25	RSV	IDFS	IDBK	IDSK	IDCH	IDCM	DCAS	IPLK
Reset Value			0	0	0	0	0	0	0

<b>RSV</b>	<p><b>Reserved</b></p> <p>Reserved. Do not access.</p>
<b>IDFS</b>	<p><b>Ignore <math>f_S</math> Detection</b></p> <p>This bit controls whether to ignore the <math>f_S</math> detection. When ignored, <math>f_S</math> error will not cause a clock error.</p> <p>Default value: 0</p> <p>0: Regard <math>f_S</math> detection</p> <p>1: Ignore <math>f_S</math> detection</p>
<b>IDBK</b>	<p><b>Ignore BCK Detection</b></p> <p>This bit controls whether to ignore the BCK detection against LRCK. The BCK must be stable between <math>32f_S</math> and <math>256f_S</math> inclusive or an error will be reported. When ignored, a BCK error will not cause a clock error.</p> <p>Default value: 0</p> <p>0: Regard BCK detection</p> <p>1: Ignore BCK detection</p>
<b>IDSK</b>	<p><b>Ignore SCK Detection</b></p> <p>This bit controls whether to ignore the SCK detection against LRCK. Only some certain SCK ratios within some error margin are allowed. When ignored, an SCK error will not cause a clock error.</p> <p>Default value: 0</p> <p>0: Regard SCK detection</p> <p>1: Ignore SCK detection</p>
<b>IDCH</b>	<p><b>Ignore Clock Halt Detection</b></p> <p>This bit controls whether to ignore the SCK halt (static or frequency is lower than acceptable) detection. When ignored an SCK halt will not cause a clock error.</p> <p>Default value: 0</p>



	0: Regard SCK halt detection 1: Ignore SCK halt detection
<b>IDCM</b>	<b>Ignore LRCK or BCK Missing Detection</b> This bit controls whether to ignore the LRCK or BCK missing detection. The LRCK or BCK need to be in low state (not only static) to be deemed missing. When ignored an LRCK or BCK missing will not cause the DAC go into powerdown mode. Default value: 0 0: Regard LRCK or BCK missing detection 1: Ignore LRCK or BCK missing detection
<b>DCAS</b>	<b>Disable Clock Divider Autoset</b> This bit enables or disables the clock auto set mode. When dealing with uncommon audio clock configuration, the auto set mode must be disabled and all clock dividers must be set manually. Additionally, some clock detectors might also need to be disabled. The clock autoset feature will not work with PLL enabled in VCOM mode. In this case this feature has to be disabled and the clock dividers must be set manually. Default value: 0 0: Enable clock auto set 1: Disable clock auto set
<b>IPLK</b>	<b>Ignore PLL Lock Detection</b> This bit controls whether to ignore the PLL lock detection. When ignored, PLL unlocks will not cause a clock error. The PLL lock flag at Page 0 / Register 4, bit 4 is always correct regardless of this bit. Default value: 0 0: PLL unlocks raise clock error 1: PLL unlocks are ignored

**Page 0 / Register 40**

Dec	Hex	b7	b6	b5	b4	b3	b2	b1	b0
40	28	RSV	RSV	AFMT1	AFMT0	RSV	RSV	ALEN1	ALEN0
Reset Value				0	0			1	0

<b>RSV</b>	<b>Reserved</b> Reserved. Do not access.
<b>AFMT[1:0]</b>	<b>I<sup>2</sup>S Data Format</b> These bits control both input and output audio interface formats for DAC operation. Default value: 00 00: I <sup>2</sup> S 01: DSP 10: RTJ 11: LTJ
<b>ALEN[1:0]</b>	<b>I<sup>2</sup>S Word Length</b> These bits control both input and output audio interface sample word lengths for DAC operation. Default value: 10 00: 16 bits 01: 20 bits 10: 24 bits 11: 32 bits

**Page 0 / Register 41**

Dec	Hex	b7	b6	b5	b4	b3	b2	b1	b0
41	29	AOFS7	AOFS6	AOFS5	AOFS4	AOFS3	AOFS2	AOFS1	AOFS0
Reset Value		0	0	0	0	0	0	0	0

<b>AOFS[7:0]</b>	<p><b>I<sup>2</sup>S Shift</b></p> <p>These bits control the offset of audio data in the audio frame for both input and output. The offset is defined as the number of BCK from the starting (MSB) of audio frame to the starting of the desired audio sample.</p> <p>Default value: 00000000</p> <p>00000000: offset = 0 BCK (no offset)</p> <p>00000001: ofsset = 1 BCK</p> <p>00000010: offset = 2 BCKs</p> <p>11111111: offset = 256 BCKs</p>
------------------	---

**Page 0 / Register 42**

Dec	Hex	b7	b6	b5	b4	b3	b2	b1	b0
42	2A	RSV	RSV	AUPL1	AUPL0	RSV	RSV	AUPR1	AUPR0
Reset Value				0	1			0	1

<b>RSV</b>	<p><b>Reserved</b></p> <p>Reserved. Do not access.</p>
<b>AUPL[1:0]</b>	<p><b>Left DAC Data Path</b></p> <p>These bits control the left channel audio data path connection.</p> <p>Default value: 01</p> <p>00: Zero data (mute)</p> <p>01: Left channel data</p> <p>10: Right channel data</p> <p>11: Reserved (do not set)</p>
<b>AUPR[1:0]</b>	<p><b>Right DAC Data Path</b></p> <p>These bits control the right channel audio data path connection.</p> <p>Default value: 01</p> <p>00: Zero data (mute)</p> <p>01: Right channel data</p> <p>10: Left channel data</p> <p>11: Reserved (do not set)</p>

**Page 0 / Register 43**

Dec	Hex	b7	b6	b5	b4	b3	b2	b1	b0
43	2B	RSV	RSV	RSV	PSEL4	PSEL3	PSEL2	PSEL1	PSEL0
Reset Value					0	0	0	0	1

<b>RSV</b>	<p><b>Reserved</b></p> <p>Reserved. Do not access.</p>
<b>PSEL[4:0]</b>	<p><b>DSP Program Selection</b></p> <p>These bits select the DSP program to use for audio processing.</p> <p>Default value: 00001</p> <p>00000: Reserved (do not set)</p> <p>00001: 8x/4x/2x FIR interpolation filter with de-emphasis</p> <p>00010: 8x/4x/2x Low latency IIR interpolation filter with de-emphasis</p> <p>00011: High attenuation x8/x4/x2 interpolation filter with de-emphasis</p> <p>00100: Reserved</p> <p>00101: Fixed process flow with configurable parameters</p> <p>00110: Reserved (do not set)</p> <p>00111: 8x Ringing-less low latency FIR interpolation filter without de-emphasis</p> <p>11111: User program in RAM</p>

	others: Reserved (do not set)
--	-------------------------------

**Page 0 / Register 44**

Dec	Hex	b7	b6	b5	b4	b3	b2	b1	b0
44	2C	RSV	RSV	RSV	RSV	RSV	CMDP2	CMDP1	CMDP0
Reset Value							0	0	0

<b>RSV</b>	<b>Reserved</b> Reserved. Do not access.
<b>CMDP[2:0]</b>	<b>Clock Missing Detection Period</b> These bits set how long both BCK and LRCK keep low before the audio clocks deemed missing and the DAC transitions to powerdown mode. Default value: 000 000: about 1 second 001: about 2 seconds 010: about 3 seconds ... 111: about 8 seconds

**Page 0 / Register 59**

Dec	Hex	b7	b6	b5	b4	b3	b2	b1	b0
59	3B	RSV	AMTL2	AMTL1	AMTL0	RSV	AMTR2	AMTR1	AMTR0
Reset Value			0	0	0		0	0	0

<b>RSV</b>	<b>Reserved</b> Reserved. Do not access.
<b>AMTL[2:0]</b>	<b>Auto Mute Time for Left Channel</b> These bits specify the length of consecutive zero samples at left channel before the channel can be auto muted. The times shown are for 48 kHz sampling rate and will scale with other rates. Default value: 000 000: 21 ms 001: 106 ms 010: 213 ms 011: 533 ms 100: 1.07 sec 101: 2.13 sec 110: 5.33 sec 111: 10.66 sec
<b>AMTR[2:0]</b>	<b>Auto Mute Time for Right Channel</b> These bits specify the length of consecutive zero samples at right channel before the channel can be auto muted. The times shown are for 48 kHz sampling rate and will scale with other rates. Default value: 000 000: 21 ms 001: 106 ms 010: 213 ms 011: 533 ms 100: 1.07 sec 101: 2.13 sec 110: 5.33 sec 111: 10.66 sec

**Page 0 / Register 60**

Dec	Hex	b7	b6	b5	b4	b3	b2	b1	b0
60	3C	RSV	RSV	RSV	RSV	RSV	RSV	PCTL1	PCTL0
Reset Value								0	0

<b>RSV</b>	<b>Reserved</b> Reserved. Do not access.
<b>PCTL[1:0]</b>	<b>Digital Volume Control</b> These bits control the behavior of the digital volume. Default value: 00 00: The volume for Left and right channels are independent 01: Right channel volume follows left channel setting 10: Left channel volume follows right channel setting 11: Reserved (The volume for Left and right channels are independent)

**Page 0 / Register 61**

Dec	Hex	b7	b6	b5	b4	b3	b2	b1	b0
61	3D	VOLL7	VOLL6	VOLL5	VOLL4	VOLL3	VOLL2	VOLL1	VOLL0
Reset Value		0	0	1	1	0	0	0	0

<b>VOLL[7:0]</b>	<b>Left Digital Volume</b> These bits control the left channel digital volume. The digital volume is 24 dB to -103 dB in -0.5 dB step. Default value: 00110000 00000000: +24.0 dB 00000001: +23.5 dB 00101111: +0.5 dB 00110000: 0.0 dB 00110001: -0.5 dB ... 11111110: -103 dB 11111111: Mute
------------------	--

**Page 0 / Register 62**

Dec	Hex	b7	b6	b5	b4	b3	b2	b1	b0
62	3E	VOLR7	VOLR6	VOLR5	VOLR4	VOLR3	VOLR2	VOLR1	VOLR0
Reset Value		0	0	1	1	0	0	0	0

<b>VOLR[7:0]</b>	<b>Right Digital Volume</b> These bits control the right channel digital volume. The digital volume is 24 dB to -103 dB in -0.5 dB step. Default value: 00110000 00000000: +24.0 dB 00000001: +23.5 dB 00101111: +0.5 dB 00110000: 0.0 dB 00110001: -0.5 dB ... 11111110: -103 dB 11111111: Mute
------------------	--

**Page 0 / Register 63**

Dec	Hex	b7	b6	b5	b4	b3	b2	b1	b0
63	3F	VNDF1	VNDF0	VNDS1	VNDS0	VNUF1	VNUF0	VNUS1	VNUS0
Reset Value		0	0	1	0	0	0	1	0

<b>VNDF[1:0]</b>	<b>Digital Volume Normal Ramp Down Frequency</b> These bits control the frequency of the digital volume updates when the volume is ramping down. The setting here is applied to soft mute request, asserted by XSMUTE pin or Page 0 / Register 3. Default value: 00 00: Update every 1 sample period 01: Update every 2 sample periods 10: Update every 4 sample periods 11: Directly set the volume to zero (Instant mute)
<b>VNDS[1:0]</b>	<b>Digital Volume Normal Ramp Down Step</b> These bits control the step of the digital volume updates when the volume is ramping down. The setting here is applied to soft mute request, asserted by XSMUTE pin or Page 0 / Register 3. Default value: 10 00: Decrement by 4 dB for each update 01: Decrement by 2 dB for each update 10: Decrement by 1 dB for each update 11: Decrement by 0.5 dB for each update
<b>VNUF[1:0]</b>	<b>Digital Volume Normal Ramp Up Frequency</b> These bits control the frequency of the digital volume updates when the volume is ramping up. The setting here is applied to soft unmute request, asserted by XSMUTE pin or Page 0 / Register 3. Default value: 00 00: Update every 1 sample period 01: Update every 2 sample periods 10: Update every 4 sample periods 11: Directly restore the volume (Instant unmute)
<b>VNUS[1:0]</b>	<b>Digital Volume Normal Ramp Up Step</b> These bits control the step of the digital volume updates when the volume is ramping up. The setting here is applied to soft unmute request, asserted by XSMUTE pin or Page 0 / Register 3. Default value: 10 00: Increment by 4 dB for each update 01: Increment by 2 dB for each update 10: Increment by 1 dB for each update 11: Increment by 0.5 dB for each update

**Page 0 / Register 64**

Dec	Hex	b7	b6	b5	b4	b3	b2	b1	b0
64	40	VEDF1	VEDF0	VEDS1	VEDS0	RSV	RSV	RSV	RSV
Reset Value		0	0	0	0				

<b>RSV</b>	<b>Reserved</b> Reserved. Do not access.
<b>VEDF[1:0]</b>	<b>Digital Volume Emergency Ramp Down Frequency</b> These bits control the frequency of the digital volume updates when the volume is ramping down due to clock error or power outage, which usually needs faster ramp down compared to normal soft mute. Default value: 00 00: Update every 1 sample period 01: Update every 2 sample periods

	10: Update every 4 sample periods
	11: Directly set the volume to zero (Instant mute)
<b>VEDS[1:0]</b>	<p><b>Digital Volume Emergency Ramp Down Step</b></p> <p>These bits control the step of the digital volume updates when the volume is ramping down due to clock error or power outage, which usually needs faster ramp down compared to normal soft mute.</p> <p>Default value: 00</p> <p>00: Decrement by 4 dB for each update</p> <p>01: Decrement by 2 dB for each update</p>
	10: Decrement by 1 dB for each update
	11: Decrement by 0.5 dB for each update

**Page 0 / Register 65**

Dec	Hex	b7	b6	b5	b4	b3	b2	b1	b0
65	41	RSV	RSV	RSV	RSV	RSV	ACTL	AMLE	AMRE
Reset Value							1	1	1

<b>RSV</b>	<p><b>Reserved</b></p> <p>Reserved. Do not access.</p>
<b>ACTL</b>	<p><b>Auto Mute Control</b></p> <p>This bit controls the behavior of the auto mute upon zero sample detection. The time length for zero detection is set with Page 0 / Register 59.</p> <p>Default value: 1</p> <p>0: Auto mute left channel and right channel independently.</p> <p>1: Auto mute left and right channels only when both channels are about to be auto muted.</p>
<b>AMLE</b>	<p><b>Auto Mute Left Channel</b></p> <p>This bit enables or disables auto mute on right channel. Note that when right channel auto mute is disabled and the Page 0 / Register 65, bit 2 is set to 1, the left channel will also never be auto muted.</p> <p>Default value: 1</p> <p>0: Disable right channel auto mute</p> <p>1: Enable right channel auto mute</p>
<b>AMRE</b>	<p><b>Auto Mute Right Channel</b></p> <p>This bit enables or disables auto mute on left channel. Note that when left channel auto mute is disabled and the Page 0 / Register 65, bit 2 is set to 1, the right channel will also never be auto muted.</p> <p>Default value: 1</p> <p>0: Disable left channel auto mute</p> <p>1: Enable left channel auto mute</p>

**Page 0 / Register 80**

Dec	Hex	b7	b6	b5	b4	b3	b2	b1	b0
80	50	RSV	RSV	RSV	RSV	G1SL3	G1SL2	G1SL1	G1SL0
Reset Value						0	0	0	0

<b>RSV</b>	<p><b>Reserved</b></p> <p>Reserved. Do not access.</p>
<b>G1SL[3:0]</b>	<p><b>GPIO1 Output Selection</b></p> <p>These bits select the signal to output to GPIO1. To actually output the selected signal, the GPIO1 must be set to output mode at Page 0 / Register 8.</p> <p>Default value: 0000</p> <p>0000: off (low)</p> <p>0001: DSP GPIO1 output</p> <p>0010: Register GPIO1 output (Page 0 / Register 86, bit 0)</p>

	0011: Auto mute flag (asserted when both L and R channels are auto muted)
	0100: Auto mute flag for left channel
	0101: Auto mute flag for right channel
	0110: Clock invalid flag (clock error or clock changing or clock missing)
	0111: Serial audio interface data output (SDOUT)
	1000: Analog mute flag for left channel (low active)
	1001: Analog mute flag for right channel (low active)
	1010: PLL lock flag
	1011: Charge pump clock
	1100: Reserved
	1101: Reserved
	1110: Under voltage flag, asserted when XSMUTE voltage is higher than 0.7 DVDD
	1111: Under voltage flag, asserted when XSMUTE voltage is higher than 0.3 DVDD

**Page 0 / Register 81**

Dec	Hex	b7	b6	b5	b4	b3	b2	b1	b0
81	51	RSV	RSV	RSV	RSV	G2SL3	G2SL2	G2SL1	G2SL0
Reset Value						0	0	0	0

<b>RSV</b>	<b>Reserved</b> Reserved. Do not access.
<b>G2SL[3:0]</b>	<b>GPIO2 Output Selection</b> These bits select the signal to output to GPIO2. To actually output the selected signal, the GPIO2 must be set to output mode at Page 0 / Register 8. Default value: 0000 0000: off (low) 0001: DSP GPIO2 output 0010: Register GPIO2 output (Page 0 / Register 86, bit 1) 0011: Auto mute flag (asserted when both L and R channels are auto muted) 0100: Auto mute flag for left channel 0101: Auto mute flag for right channel 0110: Clock invalid flag (clock error or clock changing or clock missing) 0111: Serial audio interface data output (SDOUT) 1000: Analog mute flag for left channel (low active) 1001: Analog mute flag for right channel (low active) 1010: PLL lock flag 1011: Charge pump clock 1100: Reserved 1101: Reserved 1110: Under voltage flag, asserted when XSMUTE voltage is higher than 0.7 DVDD 1111: Under voltage flag, asserted when XSMUTE voltage is higher than 0.3 DVDD

**Page 0 / Register 82**

Dec	Hex	b7	b6	b5	b4	b3	b2	b1	b0
82	52	RSV	RSV	RSV	RSV	G3SL3	G3SL2	G3SL1	G3SL0
Reset Value						0	0	0	0

<b>RSV</b>	<b>Reserved</b> Reserved. Do not access.
<b>G3SL[3:0]</b>	<b>GPIO3 Output Selection</b> These bits select the signal to output to GPIO3. To actually output the selected signal, the GPIO3 must be set to output mode at Page 0 / Register 8. Default value: 0000 0000: off (low) 0001: DSP GPIO3 output
	0010: Register GPIO3 output (Page 0 / Register 86, bit 2)
	0011: Auto mute flag (asserted when both L and R channels are auto muted)
	0100: Auto mute flag for left channel
	0101: Auto mute flag for right channel
	0110: Clock invalid flag (clock error or clock changing or clock missing)
	0111: Serial audio interface data output (SDOUT)
	1000: Analog mute flag for left channel (low active)
	1001: Analog mute flag for right channel (low active)
	1010: PLL lock flag
	1011: Charge pump clock
	1100: Reserved
	1101: Reserved
	1110: Under voltage flag, asserted when XSMUTE voltage is higher than 0.7 DVDD
	1111: Under voltage flag, asserted when XSMUTE voltage is higher than 0.3 DVDD

**Page 0 / Register 83**

Dec	Hex	b7	b6	b5	b4	b3	b2	b1	b0
83	53	RSV	RSV	RSV	RSV	G4SL3	G4SL2	G4SL1	G4SL0
Reset Value						0	0	0	0

<b>RSV</b>	<b>Reserved</b> Reserved. Do not access.
<b>G4SL[3:0]</b>	<b>GPIO4 Output Selection</b> These bits select the signal to output to GPIO4. To actually output the selected signal, the GPIO4 must be set to output mode at Page 0 / Register 8. Default value: 0000 0000: off (low) 0001: DSP GPIO4 output
	0010: Register GPIO4 output (Page 0 / Register 86, bit 3)
	0011: Auto mute flag (asserted when both L and R channels are auto muted)
	0100: Auto mute flag for left channel
	0101: Auto mute flag for right channel
	0110: Clock invalid flag (clock error or clock changing or clock missing)
	0111: Serial audio interface data output (SDOUT)
	1000: Analog mute flag for left channel (low active)
	1001: Analog mute flag for right channel (low active)
	1010: PLL lock flag
	1011: Charge pump clock
	1100: Reserved
	1101: Reserved
	1110: Under voltage flag, asserted when XSMUTE voltage is higher than 0.7 DVDD
	1111: Under voltage flag, asserted when XSMUTE voltage is higher than 0.3 DVDD



**Page 0 / Register 84**

Dec	Hex	b7	b6	b5	b4	b3	b2	b1	b0
84	54	RSV	RSV	RSV	RSV	G5SL3	G5SL2	G5SL1	G5SL0
Reset Value						0	0	0	0

<b>RSV</b>	<b>Reserved</b> Reserved. Do not access.
<b>G5SL[3:0]</b>	<b>GPIO5 Output Selection</b> These bits select the signal to output to GPIO5. To actually output the selected signal, the GPIO5 must be set to output mode at Page 0 / Register 8. Default value: 0000 0000: off (low) 0001: DSP GPIO5 output 0010: Register GPIO5 output (Page 0 / Register 86, bit 4) 0011: Auto mute flag (asserted when both L and R channels are auto muted) 0100: Auto mute flag for left channel 0101: Auto mute flag for right channel 0110: Clock invalid flag (clock error or clock changing or clock missing) 0111: Serial audio interface data output (SDOUT) 1000: Analog mute flag for left channel (low active) 1001: Analog mute flag for right channel (low active) 1010: PLL lock flag 1011: Charge pump clock 1100: Reserved 1101: Reserved 1110: Under voltage flag, asserted when XSMUTE voltage is higher than 0.7 DVDD 1111: Under voltage flag, asserted when XSMUTE voltage is higher than 0.3 DVDD

**Page 0 / Register 85**

Dec	Hex	b7	b6	b5	b4	b3	b2	b1	b0
85	55	RSV	RSV	RSV	RSV	G6SL3	G6SL2	G6SL1	G6SL0
Reset Value						0	0	0	0

<b>RSV</b>	<b>Reserved</b> Reserved. Do not access.
<b>G6SL[3:0]</b>	<b>GPIO6 Output Selection</b> These bits select the signal to output to GPIO6. To actually output the selected signal, the GPIO6 must be set to output mode at Page 0 / Register 8. Default value: 0000 0000: off (low) 0001: DSP GPIO6 output 0010: Register GPIO6 output (Page 0 / Register 86, bit 5) 0011: Auto mute flag (asserted when both L and R channels are auto muted) 0100: Auto mute flag for left channel 0101: Auto mute flag for right channel 0110: Clock invalid flag (clock error or clock changing or clock missing) 0111: Serial audio interface data output (SDOUT) 1000: Analog mute flag for left channel (low active) 1001: Analog mute flag for right channel (low active) 1010: PLL lock flag

	1011: Charge pump clock
	1100: Reserved
	1101: Reserved
	1110: Under voltage flag, asserted when XSMUTE voltage is higher than 0.7 DVDD
	1111: Under voltage flag, asserted when XSMUTE voltage is higher than 0.3 DVDD

**Page 0 / Register 86**

Dec	Hex	b7	b6	b5	b4	b3	b2	b1	b0
86	56	RSV	RSV	GOUT5	GOUT4	GOUT3	GOUT2	GOUT1	GOUT0
Reset Value				0	0	0	0	0	0

<b>RSV</b>	<b>Reserved</b> Reserved. Do not access.
<b>GOUT[5:0]</b>	<b>GPIO Output Control</b> This bit controls the GPIO6 output when the selection at Page 0 / Register 85 is set to 0010 (register output) Default value: 000000 0: Output low 1: Output high

**Page 0 / Register 87**

Dec	Hex	b7	b6	b5	b4	b3	b2	b1	b0
87	57	RSV	RSV	GINV5	GINV4	GINV3	GINV2	GINV1	GINV0
Reset Value				0	0	0	0	0	0

<b>RSV</b>	<b>Reserved</b> Reserved. Do not access.
<b>GINV[5:0]</b>	<b>GPIO Output Inversion</b> This bit controls the polarity of GPIO6 output. When set to 1, the output will be inverted for any signal being selected. Default value: 000000 0: Non-inverted 1: Inverted

**Page 0 / Register 90**

Dec	Hex	b7	b6	b5	b4	b3	b2	b1	b0
90	5A	RSV	RSV	RSV	L1OV	R1OV	L2OV	R2OV	SFOV
Reset Value									

<b>RSV</b>	<b>Reserved</b> Reserved. Do not access.
<b>L1OV</b>	<b>Left1 Overflow (Read Only)</b> This bit indicates whether the left channel of DSP first output port has overflow. This bit is sticky and is cleared when read. 0: No overflow 1: Overflow occurred
<b>R1OV</b>	<b>Right1 Overflow (Read Only)</b> The bit indicates whether the right channel of DSP first output port has overflow. This bit is sticky and is cleared when read. 0: No overflow 1: Overflow occurred
<b>L2OV</b>	<b>Left2 Overflow (Read Only)</b> This bit indicates whether the left channel of DSP second output port has overflow. This bit is sticky and is cleared when read. 0: No overflow

	1: Overflow occurred
<b>R2OV</b>	<b>Right2 Overflow (Read Only)</b> The bit indicates whether the right channel of DSP second output port has overflow. This bit is sticky and is cleared when read. 0: No overflow 1: Overflow occurred
<b>SFOV</b>	<b>Shifter Overflow (Read Only)</b> This bit indicates whether overflow occurred in the DSP shifter (possible sample corruption). This bit is sticky and is cleared when read. 0: No overflow 1: Overflow occurred

**Page 0 / Register 91**

Dec	Hex	b7	b6	b5	b4	b3	b2	b1	b0
91	5B	RSV	DTFS2	DTFS1	DTFS0	DTSR3	DTSR2	DTSR1	DTSR0
Reset Value									

<b>RSV</b>	<b>Reserved</b> Reserved. Do not access.
<b>DTFS[2:0]</b>	<b>Detected <math>f_s</math> (Read Only)</b> These bits indicate the currently detected audio sampling rate. 000: Error (Out of valid range) 001: 8 kHz 010: 16 kHz 011: 32-48 kHz 100: 88.2-96 kHz 101: 176.4-192 kHz 110: 384 kHz
<b>DTSR[3:0]</b>	<b>Detected SCK Ratio (Read Only)</b> These bits indicate the currently detected SCK ratio. Note that even if the SCK ratio is not indicated as error, clock error might still be flagged due to incompatible combination with the sampling rate. Specifically the SCK ratio must be high enough to allow enough DSP cycles for minimal audio processing when PLL is disabled. The absolute SCK frequency must also be lower than 50 MHz. 0000: Ratio error (The SCK ratio is not allowed) 0001: SCK = $32f_s$ 0010: SCK = $48f_s$ 0011: SCK = $64f_s$ 0100: SCK = $128f_s$ 0101: SCK = $192f_s$ 0110: SCK = $256f_s$ 0111: SCK = $384f_s$ 1000: SCK = $512f_s$ 1001: SCK = $768f_s$ 1010: SCK = $1024f_s$ 1011: SCK = $1152f_s$ 1100: SCK = $1536f_s$ 1101: SCK = $2048f_s$ 1110: SCK = $3072f_s$

**Page 0 / Register 92**

Dec	Hex	b7	b6	b5	b4	b3	b2	b1	b0
92	5C	RSV	RSV	RSV	RSV	RSV	RSV	RSV	DTBR8
Reset Value									

**Page 0 / Register 93**

93	5D	DTBR7	DTBR6	DTBR5	DTBR4	DTBR3	DTBR2	DTBR1	DTBR0
Reset Value									

<b>RSV</b>	<b>Reserved</b> Reserved. Do not access.
<b>DTBR[8:0]</b>	<b>Detected BCK Ratio (MSB) (Read Only)</b> These bits indicate the currently detected BCK ratio, that is, the number of BCK clocks in one audio frame. Note that for the extreme case of BCK = 1 f <sub>s</sub> (not a usable scenario), the detected ratio will be unreliable.

**Page 0 / Register 94**

Dec	Hex	b7	b6	b5	b4	b3	b2	b1	b0
94	5E	RSV	CDST6	CDST5	CDST4	CDST3	CDST2	CDST1	CDST0
Reset Value									

<b>RSV</b>	<b>Reserved</b> Reserved. Do not access.
<b>CDST[6:0]</b>	<b>Clock Detector Status (Read Only)</b> This bit indicates whether the SCK clock is present or not. 0: SCK is present 1: SCK is missing (halted)

**Page 0 / Register 108**

Dec	Hex	b7	b6	b5	b4	b3	b2	b1	b0
108	6C	RSV	RSV	RSV	RSV	RSV	RSV	AMLM	AMRM
Reset Value									

<b>RSV</b>	<b>Reserved</b> Reserved. Do not access.
<b>AMLM</b>	<b>Left Analog Mute Monitor (Read Only)</b> This bit is a monitor for left channel analog mute status. 0: Mute 1: Unmute
<b>AMRM</b>	<b>Right Analog Mute Monitor (Read Only)</b> This bit is a monitor for right channel analog mute status. 0: Mute 1: Unmute

**Page 0 / Register 119**

Dec	Hex	b7	b6	b5	b4	b3	b2	b1	b0
119	77	RSV	RSV	GPIN5	GPIN4	GPIN3	GPIN2	GPIN1	RSV
Reset Value									

<b>RSV</b>	<b>Reserved</b> Reserved. Do not access.
<b>GPIN[5:0]</b>	<b>GPIO Input States (Read Only)</b> This bit indicates the logic level at GPIO6 pin. 0: Low 1: High

**Page 0 / Register 120**

Dec	Hex	b7	b6	b5	b4	b3	b2	b1	b0
120	78	RSV	RSV	RSV	AMFL	RSV	RSV	RSV	AMFR
Reset Value									

<b>RSV</b>	<b>Reserved</b> Reserved. Do not access.
<b>AMFL</b>	<b>Auto Mute Flag for Left Channel (Read Only)</b> This bit indicates the auto mute status for left channel. 0: Not auto muted 1: Auto muted
<b>AMFR</b>	<b>Auto Mute Flag for Right Channel (Read Only)</b> This bit indicates the auto mute status for right channel. 0: Not auto muted 1: Auto muted

**Page 1 / Register 1**

Dec	Hex	b7	b6	b5	b4	b3	b2	b1	b0
1	01	RSV	RSV	RSV	RSV	RSV	RSV	RSV	OSEL
Reset Value									0

<b>RSV</b>	<b>Reserved</b> Reserved. Do not access.
<b>OSEL</b>	<b>Output Amplitude Type</b> This bit selects the output amplitude type. The clock autoset feature will not work with PLL enabled in VCOM mode. In this case this feature has to be disabled via Page 0 / Register 37 and the clock dividers must be set manually.  Default value: 0 0: VREF mode (Constant output amplitude against AVDD variation) 1: VCOM mode (Output amplitude is proportional to AVDD variation)

**Page 1 / Register 2**

Dec	Hex	b7	b6	b5	b4	b3	b2	b1	b0
2	02	RSV	RSV	RSV	LAGN	RSV	RSV	RSV	RAGN
Reset Value									0

<b>RSV</b>	<b>Reserved</b> Reserved. Do not access.
<b>LAGN</b>	<b>Analog Gain Control for Left Channel</b> This bit controls the left channel analog gain.  Default value: 0 0: 0 dB 1: -6 dB
<b>RAGN</b>	<b>Analog Gain Control for Right Channel</b> This bit controls the right channel analog gain.  Default value: 0 0: 0 dB 1: -6 dB

**Page 1 / Register 5**

Dec	Hex	b7	b6	b5	b4	b3	b2	b1	b0
5	05	RSV	RSV	RSV	RSV	RSV	RSV	UEPD	UIPD
Reset Value								0	0

<b>RSV</b>	<b>Reserved</b> Reserved. Do not access.
<b>UEPD</b>	<b>External UVP Control</b> This bit enables or disables detection of power supply drop via XSMUTE pin (External Under Voltage Protection).  Default value: 0 0: Enabled 1: Disabled
<b>UIPD</b>	<b>Internal UVP Control</b> This bit enables or disables internal detection of AVDD voltage drop (Internal Under Voltage Protection).  Default value: 0 0: Enabled 1: Disabled

**Page 1 / Register 6**

Dec	Hex	b7	b6	b5	b4	b3	b2	b1	b0
6	06	RSV	RSV	RSV	RSV	RSV	RSV	RSV	AMCT
Reset Value									0

<b>RSV</b>	<b>Reserved</b> Reserved. Do not access.
<b>AMCT</b>	<b>Analog Mute Control</b> This bit enables or disables analog mute following digital mute.  Default value: 0 0: Enabled 1: Disabled

**Page 1 / Register 7**

Dec	Hex	b7	b6	b5	b4	b3	b2	b1	b0
7	07	RSV	RSV	RSV	AGBL	RSV	RSV	RSV	AGBR
Reset Value					0				0

<b>RSV</b>	<b>Reserved</b> Reserved. Do not access.
<b>AGBL</b>	<b>Analog +10% Gain for Left Channel</b> This bit enables or disables amplitude boost mode for left channel.  Default value: 0 0: Normal amplitude 1: +10% (+0.8 dB) boosted amplitude
<b>AGBR</b>	<b>Analog +10% Gain for Right Channel</b> This bit enables or disables amplitude boost mode for right channel.  Default value: 0 0: Normal amplitude 1: +10% (+0.8 dB) boosted amplitude

**Page 1 / Register 8**

Dec	Hex	b7	b6	b5	b4	b3	b2	b1	b0
8	08	RSV	RSV	RSV	RSV	RSV	RSV	RSV	RCMF
Reset Value									0

<b>RSV</b>	<b>Reserved</b> Reserved. Do not access.
<b>RCMF</b>	<b>VCOM Reference Ramp Up</b> This bit controls the VCOM voltage ramp up speed. Default value: 0 0: Normal ramp up, ~600ms with external capacitance = 1uF 1: Fast ramp up, ~3ms with external capacitance = 1uF

**Page 1 / Register 9**

Dec	Hex	b7	b6	b5	b4	b3	b2	b1	b0
9	09	RSV	RSV	RSV	RSV	RSV	RSV	RSV	VCPD
Reset Value									1

<b>RSV</b>	<b>Reserved</b> Reserved. Do not access.
<b>VCPD</b>	<b>Power down control for VCOM</b> This bit controls VCOM powerdown switch. Default value: 1 0: VCOM is powered on 1: VCOM is powered down

**Page 44 / Register 1**

Dec	Hex	b7	b6	b5	b4	b3	b2	b1	b0
1	01	RSV	RSV	RSV	RSV	ACRM	AMDC	ACRS	ACSW
Reset Value							0		0

<b>RSV</b>	<b>Reserved</b> Reserved. Do not access.
<b>ACRM</b>	<b>Active CRAM Monitor (Read Only)</b> This bit indicates which CRAM is being accessed by the DSP when adaptive mode is disabled. When adaptive mode is enabled, this bit has no meaning. 0: CRAM A is being used by the DSP 1: CRAM B is being used by the DSP
<b>AMDC</b>	<b>Adaptive Mode Control</b> This bit controls the DSP adaptive mode. When in adaptive mode, only CRAM A is accessible via serial interface when the DSP is disabled (DAC in standby state), while when the DSP is enabled (DAC is run state) the CRAM A can only be accessed by the DSP and the CRAM B can only be accessed by the serial interface, or vice versa depending on the value of CRAMSTAT. When not in adaptive mode, both CRAM A and B can be accessed by the serial interface when the DSP is disabled, but when the DSP is enabled, no CRAM can be accessed by serial interface. The DSP can access either CRAM, which can be monitored at SWPMON. Default value: 0 0: Adaptive mode disabled 1: Adaptive mode enabled
<b>ACRS</b>	<b>Active CRAM Selection (Read Only)</b> This bit indicates which CRAM currently serves as the active one. The other CRAM serves as an update buffer, and can accessed by serial interface (SPI or I2C) 0: CRAM A is active and being used by the DSP 1: CRAM B is active and being used by the DSP
<b>ACSW</b>	<b>Switch Active CRAM</b> This bit is a role-switch request between the two buffers, switching the active buffer role between CRAM A and CRAM B. This bit clears automatically when the switching process completed. Default value: 0 0: No switching requested or switching completed 1: Switching is being requested

**PACKAGING INFORMATION**

Orderable Device	Status (1)	Package Type	Package Drawing	Pins	Package Qty	Eco Plan (2)	Lead/Ball Finish	MSL Peak Temp (3)	Samples (Requires Login)
PCM5141PW	ACTIVE	TSSOP	PW	28	50	Green (RoHS & no Sb/Br)	CU NIPDAU	Level-1-260C-UNLIM	
PCM5141PWR	ACTIVE	TSSOP	PW	28	2000	Green (RoHS & no Sb/Br)	CU NIPDAU	Level-1-260C-UNLIM	
PCM5142PW	ACTIVE	TSSOP	PW	28	50	Green (RoHS & no Sb/Br)	CU NIPDAU	Level-1-260C-UNLIM	
PCM5142PWR	ACTIVE	TSSOP	PW	28	2000	Green (RoHS & no Sb/Br)	CU NIPDAU	Level-1-260C-UNLIM	

(1) The marketing status values are defined as follows:

**ACTIVE:** Product device recommended for new designs.

**LIFEBUY:** TI has announced that the device will be discontinued, and a lifetime-buy period is in effect.

**NRND:** Not recommended for new designs. Device is in production to support existing customers, but TI does not recommend using this part in a new design.

**PREVIEW:** Device has been announced but is not in production. Samples may or may not be available.

**OBSELETE:** TI has discontinued the production of the device.

(2) Eco Plan - The planned eco-friendly classification: Pb-Free (RoHS), Pb-Free (RoHS Exempt), or Green (RoHS & no Sb/Br) - please check <http://www.ti.com/productcontent> for the latest availability information and additional product content details.

**TBD:** The Pb-Free/Green conversion plan has not been defined.

**Pb-Free (RoHS):** TI's terms "Lead-Free" or "Pb-Free" mean semiconductor products that are compatible with the current RoHS requirements for all 6 substances, including the requirement that lead not exceed 0.1% by weight in homogeneous materials. Where designed to be soldered at high temperatures, TI Pb-Free products are suitable for use in specified lead-free processes.

**Pb-Free (RoHS Exempt):** This component has a RoHS exemption for either 1) lead-based flip-chip solder bumps used between the die and package, or 2) lead-based die adhesive used between the die and leadframe. The component is otherwise considered Pb-Free (RoHS compatible) as defined above.

**Green (RoHS & no Sb/Br):** TI defines "Green" to mean Pb-Free (RoHS compatible), and free of Bromine (Br) and Antimony (Sb) based flame retardants (Br or Sb do not exceed 0.1% by weight in homogeneous material)

(3) MSL, Peak Temp. -- The Moisture Sensitivity Level rating according to the JEDEC industry standard classifications, and peak solder temperature.

**Important Information and Disclaimer:** The information provided on this page represents TI's knowledge and belief as of the date that it is provided. TI bases its knowledge and belief on information provided by third parties, and makes no representation or warranty as to the accuracy of such information. Efforts are underway to better integrate information from third parties. TI has taken and continues to take reasonable steps to provide representative and accurate information but may not have conducted destructive testing or chemical analysis on incoming materials and chemicals. TI and TI suppliers consider certain information to be proprietary, and thus CAS numbers and other limited information may not be available for release.

In no event shall TI's liability arising out of such information exceed the total purchase price of the TI part(s) at issue in this document sold by TI to Customer on an annual basis.



## TAPE AND REEL INFORMATION



### QUADRANT ASSIGNMENTS FOR PIN 1 ORIENTATION IN TAPE



\*All dimensions are nominal

Device	Package Type	Package Drawing	Pins	SPQ	Reel Diameter (mm)	Reel Width W1 (mm)	A0 (mm)	B0 (mm)	K0 (mm)	P1 (mm)	W (mm)	Pin1 Quadrant
PCM5141PWR	TSSOP	PW	28	2000	330.0	16.4	6.9	10.2	1.8	12.0	16.0	Q1
PCM5142PWR	TSSOP	PW	28	2000	330.0	16.4	6.9	10.2	1.8	12.0	16.0	Q1

TAPE AND REEL BOX DIMENSIONS



\*All dimensions are nominal

Device	Package Type	Package Drawing	Pins	SPQ	Length (mm)	Width (mm)	Height (mm)
PCM5141PWR	TSSOP	PW	28	2000	367.0	367.0	38.0
PCM5142PWR	TSSOP	PW	28	2000	367.0	367.0	38.0

PW (R-PDSO-G28)

PLASTIC SMALL OUTLINE



4040064-7/G 02/11

- NOTES:
- A. All linear dimensions are in millimeters. Dimensioning and tolerancing per ASME Y14.5M-1994.
  - B. This drawing is subject to change without notice.
  - C. Body length does not include mold flash, protrusions, or gate burrs. Mold flash, protrusions, or gate burrs shall not exceed 0,15 each side.
  - D. Body width does not include interlead flash. Interlead flash shall not exceed 0,25 each side.
  - E. Falls within JEDEC MO-153

PW (R-PDSO-G28)

PLASTIC SMALL OUTLINE

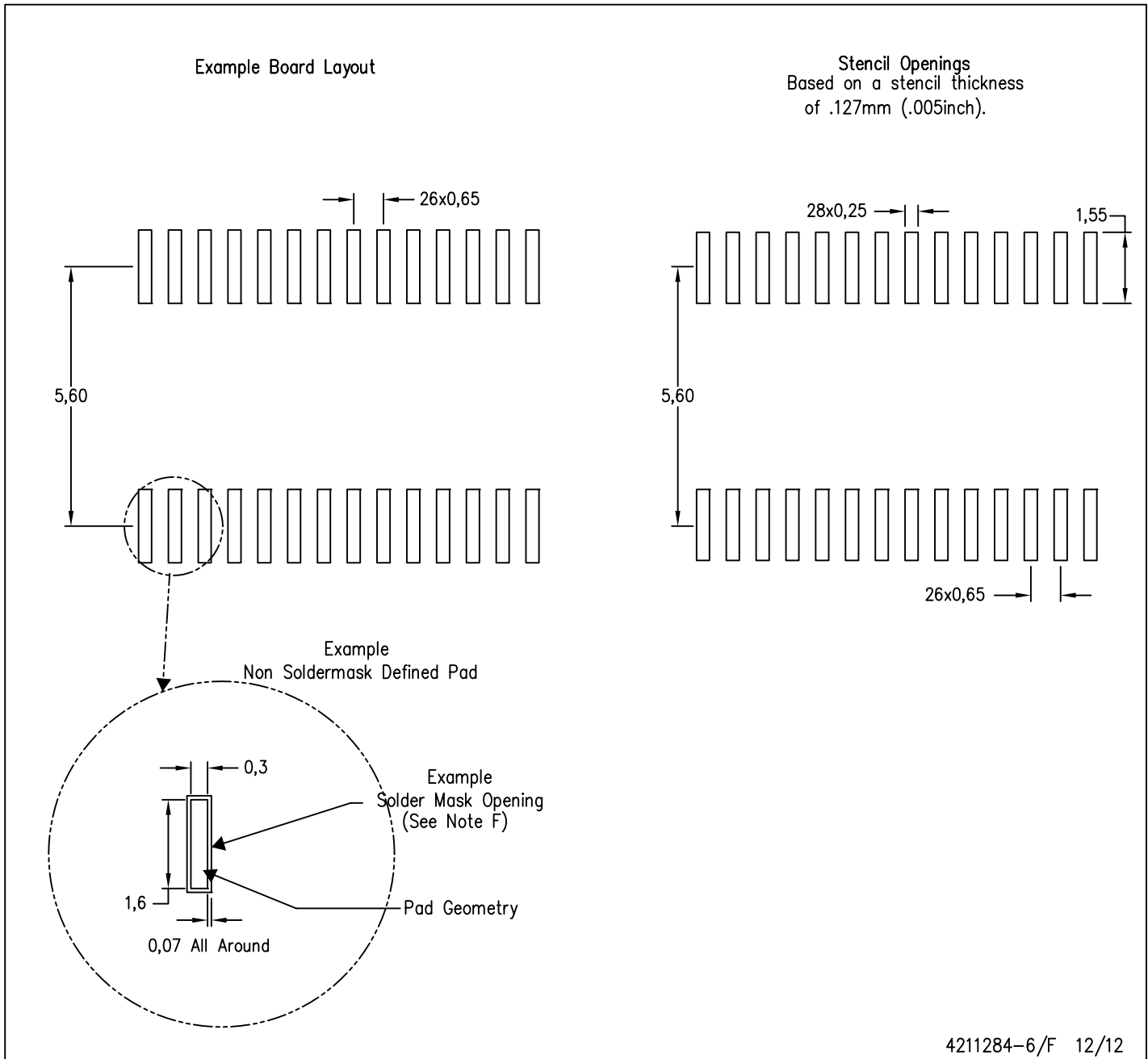

- NOTES:
- A. All linear dimensions are in millimeters.
  - B. This drawing is subject to change without notice.
  - C. Publication IPC-7351 is recommended for alternate design.
  - D. Laser cutting apertures with trapezoidal walls and also rounding corners will offer better paste release. Customers should contact their board assembly site for stencil design recommendations. Refer to IPC-7525 for other stencil recommendations.
  - E. Customers should contact their board fabrication site for solder mask tolerances between and around signal pads.

PW (R-PDSO-G28)

PLASTIC SMALL OUTLINE

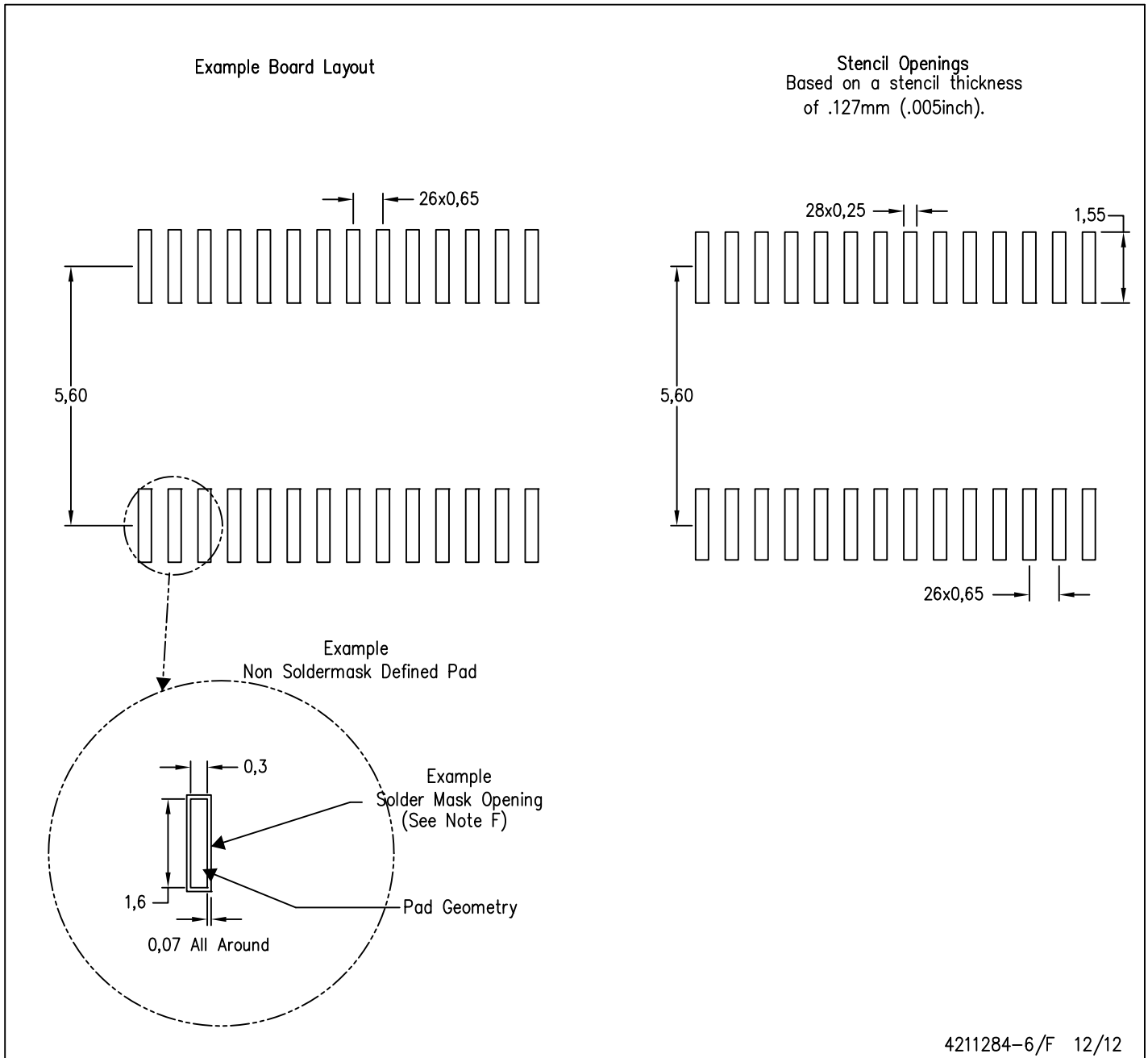

- NOTES:
- A. All linear dimensions are in millimeters.
  - B. This drawing is subject to change without notice.
  - C. Publication IPC-7351 is recommended for alternate design.
  - D. Laser cutting apertures with trapezoidal walls and also rounding corners will offer better paste release. Customers should contact their board assembly site for stencil design recommendations. Refer to IPC-7525 for other stencil recommendations.
  - E. Customers should contact their board fabrication site for solder mask tolerances between and around signal pads.

## IMPORTANT NOTICE

Texas Instruments Incorporated and its subsidiaries (TI) reserve the right to make corrections, enhancements, improvements and other changes to its semiconductor products and services per JESD46, latest issue, and to discontinue any product or service per JESD48, latest issue. Buyers should obtain the latest relevant information before placing orders and should verify that such information is current and complete. All semiconductor products (also referred to herein as "components") are sold subject to TI's terms and conditions of sale supplied at the time of order acknowledgment.

TI warrants performance of its components to the specifications applicable at the time of sale, in accordance with the warranty in TI's terms and conditions of sale of semiconductor products. Testing and other quality control techniques are used to the extent TI deems necessary to support this warranty. Except where mandated by applicable law, testing of all parameters of each component is not necessarily performed.

TI assumes no liability for applications assistance or the design of Buyers' products. Buyers are responsible for their products and applications using TI components. To minimize the risks associated with Buyers' products and applications, Buyers should provide adequate design and operating safeguards.

TI does not warrant or represent that any license, either express or implied, is granted under any patent right, copyright, mask work right, or other intellectual property right relating to any combination, machine, or process in which TI components or services are used. Information published by TI regarding third-party products or services does not constitute a license to use such products or services or a warranty or endorsement thereof. Use of such information may require a license from a third party under the patents or other intellectual property of the third party, or a license from TI under the patents or other intellectual property of TI.

Reproduction of significant portions of TI information in TI data books or data sheets is permissible only if reproduction is without alteration and is accompanied by all associated warranties, conditions, limitations, and notices. TI is not responsible or liable for such altered documentation. Information of third parties may be subject to additional restrictions.

Resale of TI components or services with statements different from or beyond the parameters stated by TI for that component or service voids all express and any implied warranties for the associated TI component or service and is an unfair and deceptive business practice. TI is not responsible or liable for any such statements.

Buyer acknowledges and agrees that it is solely responsible for compliance with all legal, regulatory and safety-related requirements concerning its products, and any use of TI components in its applications, notwithstanding any applications-related information or support that may be provided by TI. Buyer represents and agrees that it has all the necessary expertise to create and implement safeguards which anticipate dangerous consequences of failures, monitor failures and their consequences, lessen the likelihood of failures that might cause harm and take appropriate remedial actions. Buyer will fully indemnify TI and its representatives against any damages arising out of the use of any TI components in safety-critical applications.

In some cases, TI components may be promoted specifically to facilitate safety-related applications. With such components, TI's goal is to help enable customers to design and create their own end-product solutions that meet applicable functional safety standards and requirements. Nonetheless, such components are subject to these terms.

No TI components are authorized for use in FDA Class III (or similar life-critical medical equipment) unless authorized officers of the parties have executed a special agreement specifically governing such use.

Only those TI components which TI has specifically designated as military grade or "enhanced plastic" are designed and intended for use in military/aerospace applications or environments. Buyer acknowledges and agrees that any military or aerospace use of TI components which have **not** been so designated is solely at the Buyer's risk, and that Buyer is solely responsible for compliance with all legal and regulatory requirements in connection with such use.

TI has specifically designated certain components as meeting ISO/TS16949 requirements, mainly for automotive use. In any case of use of non-designated products, TI will not be responsible for any failure to meet ISO/TS16949.

### Products

Audio	<a href="http://www.ti.com/audio">www.ti.com/audio</a>
Amplifiers	<a href="http://amplifier.ti.com">amplifier.ti.com</a>
Data Converters	<a href="http://dataconverter.ti.com">dataconverter.ti.com</a>
DLP® Products	<a href="http://www.dlp.com">www.dlp.com</a>
DSP	<a href="http://dsp.ti.com">dsp.ti.com</a>
Clocks and Timers	<a href="http://www.ti.com/clocks">www.ti.com/clocks</a>
Interface	<a href="http://interface.ti.com">interface.ti.com</a>
Logic	<a href="http://logic.ti.com">logic.ti.com</a>
Power Mgmt	<a href="http://power.ti.com">power.ti.com</a>
Microcontrollers	<a href="http://microcontroller.ti.com">microcontroller.ti.com</a>
RFID	<a href="http://www.ti-rfid.com">www.ti-rfid.com</a>
OMAP Applications Processors	<a href="http://www.ti.com/omap">www.ti.com/omap</a>
Wireless Connectivity	<a href="http://www.ti.com/wirelessconnectivity">www.ti.com/wirelessconnectivity</a>

### Applications

Automotive and Transportation	<a href="http://www.ti.com/automotive">www.ti.com/automotive</a>
Communications and Telecom	<a href="http://www.ti.com/communications">www.ti.com/communications</a>
Computers and Peripherals	<a href="http://www.ti.com/computers">www.ti.com/computers</a>
Consumer Electronics	<a href="http://www.ti.com/consumer-apps">www.ti.com/consumer-apps</a>
Energy and Lighting	<a href="http://www.ti.com/energy">www.ti.com/energy</a>
Industrial	<a href="http://www.ti.com/industrial">www.ti.com/industrial</a>
Medical	<a href="http://www.ti.com/medical">www.ti.com/medical</a>
Security	<a href="http://www.ti.com/security">www.ti.com/security</a>
Space, Avionics and Defense	<a href="http://www.ti.com/space-avionics-defense">www.ti.com/space-avionics-defense</a>
Video and Imaging	<a href="http://www.ti.com/video">www.ti.com/video</a>

### TI E2E Community

[e2e.ti.com](http://e2e.ti.com)